

# TS8000

**Getting  
Started**

HA471056U001



ENGINEERING YOUR SUCCESS.



© Copyright Parker SSD Drives 2008

All rights strictly reserved. No part of this document may be stored in a retrieval system, or transmitted in any form or by any means to persons not employed by a Parker SSD Drives company without written permission from Parker SSD Drives.

Although every effort has been taken to ensure the accuracy of this document it may be necessary, without notice, to make amendments or correct omissions. Parker SSD Drives cannot accept responsibility for damage, injury, or expenses resulting there from.

Companies, names and data used as examples herein are fictitious unless otherwise stated. All trademarks and copyrights are acknowledged as the property of their respective owners.

---

## Table of Contents

<b>Product Overview .....</b>	<b>3</b>
General Description .....	3
Safety Information.....	4
Contents Of Package .....	4
<b>Specifications .....</b>	<b>5</b>
Power Requirements .....	5
Battery.....	5
LCD Module Display.....	5
Keypad .....	5
Touchscreen .....	5
Memory.....	5
Communications.....	6
Environmental Conditions .....	6
Certifications And Compliances .....	6
Construction.....	7
Mounting Requirements.....	7
Weight.....	7
Dimensions .....	7
<b>Installation And Power.....</b>	<b>8</b>
Mounting Instructions .....	8
Connecting To Ground .....	8
Power Supply Requirements.....	8
<b>Communications.....</b>	<b>10</b>
Configuring a TS8000.....	10
Cables And Drivers.....	10
The CompactFlash Card .....	10
Ethernet Communications .....	10
RS-232 Communications .....	11
RS-422/485 Communications .....	12
<b>Software / Unit Operations.....</b>	<b>13</b>
DSI8000 Software.....	13
Keypad Buttons.....	13
Front Panel LEDs .....	13
Display.....	13
Touchscreen .....	14
Troubleshooting The TS8000.....	14
Battery And Time Keeping .....	14
<b>Options And Accessories .....</b>	<b>16</b>
CompactFlash Socket.....	16

---

Optional Communications Cards.....	16
<b>Appendix A – TS8003 Specifications .....</b>	<b>17</b>
TS8003 Dimensions .....	17
TS8003 Mounting Specifications.....	17
TS8003 Port Pin-Outs.....	18
<b>Appendix B – TS8006 Specifications .....</b>	<b>19</b>
TS8006 Dimensions .....	19
TS8006 Mounting Specifications.....	19
TS8006 Port Pin-Outs.....	20
<b>Appendix C – TS8008 Specifications .....</b>	<b>21</b>
TS8008 Dimensions .....	21
TS8008 Mounting Specifications.....	21
TS8008 Port Pin-Outs.....	22
<b>Appendix D – TS8010 Specifications.....</b>	<b>23</b>
TS8010 Dimensions .....	23
TS8010 Mounting Specifications.....	23
TS8010 Port Pin-Outs.....	24
<b>Appendix E – TS8015 Specifications .....</b>	<b>25</b>
TS8015 Dimensions.....	25
TS8015 Mounting Specifications.....	25
TS8015 Port Pin-Outs .....	26

## Product Overview



- **Configured with DSI8000 software.**
- **3 onboard RS-232/422/485 comms ports.**
- **Onboard 10/100 Base-T Ethernet** for device comms, web hosting, and unit networking.
- **USB Port** to download configuration files or transfer data from the unit.
- **4 Mb** (TS8003), **8 Mb** (TS8006, TS8008, TS8010), or **32 Mb** (TS8015) onboard flash memory (expandable with optional CompactFlash card).
- **3.2 inch LCD display** (TS8003) 128x64x2 color.
- **5.7 inch TFT display** (TS8006) 320x240x256 color.
- **7.7 inch DSTN display** (TS8008) 640x480x256 color.
- **10.4 inch TFT display** (TS8010) 640x480x256 color.
- **15 inch TFT display** (TS8015) 1024x768x32K color.
- **32** (TS8003), **5** (TS8006), **7** (TS8008), **8** (TS8010), or **10** (TS8015) **button keypads** for on screen menus.
- **24vdc power supply** (+/- 20%).
- **Resistive Analog Touchscreen** (TS8006, TS8008, TS8010, TS8015).

## General Description

The TS8000 Operator Interfaces combine unique capabilities normally expected from high-end units with a very affordable price. They are built around a high performance core with integrated functionality. This core allows the TS8000 series to leverage many of the features typically found in many PC based SCADA systems.

The TS8000 series are able to communicate with many different types of hardware using high-speed RS-232/422/485 and 10/100 Base-T Ethernet communications ports. In addition, the TS8000's feature a USB port for fast download of configuration files and access to trending and data logging. A CompactFlash socket is provided so that CF cards can be used to collect your trends and data logs as well as to increase the memory available for configuration files.

In addition to accessing and controlling of external resources, the TS8000 series allows a user to easily view and enter information. Users can enter data through the touchscreen or front panel keypad.

## Safety Information

All safety related regulations, local codes and instructions that appear in the manual or on equipment must be observed to ensure personal safety and to prevent damage to either the instrument or equipment connected to it. If equipment is used in a manner not specified by the manufacturer, the protection provided by the equipment may be impaired.

Do not use the controller to directly command motors, valves, or other process actuators not equipped with safeguards. To do so can be potentially harmful to persons or equipment in the event of a fault to the controller.

## Contents Of Package

The TS8000 unit will come shipped with the following additional equipment:

- TS8000 Operator Interface terminal (TS8003/00/00, TS8006/00/00, TS8008/00/00, TS8010/00/00, or TS8015/00/00).
- 2 meter USB programming cable (CM471053).
- 5 meter serial communications cable (CM471054).
- DSI8000 software CD with Value Added Apps (RI471055).
- Getting Started bulletin (HA471056U000).
- Panel cutout template.
- Panel mounting hardware packet.
- Panel mounting gasket.
- Power supply terminal block.

## Specifications

The following specifications pertain to the TS8000 series HMI. SSD Drives retains the right to modify specifications at any time, without prior notice.

### Power Requirements

+24vdc (+/- 20%) @ 9.5W max (TS8003), 14W max (TS8006), 24W max (TS8008), 33W max (TS8010), 67W max (TS8015) - must use Class 2 or SELV rated power supply.

Power connection is available via removable 3-position terminal block.

Note: The TS8000's "common" is not connected to the unit's chassis. Refer to "**Connecting To Ground**" in the "**Installation And Power**" section of this document.

### Battery

Lithium CR2025 "button" cell. Typical lifetime of 10 years.

### LCD Module Display

Model	TS8003	TS8006	TS8008	TS8010	TS8015
Size	3.2 inch	5.7 inch	7.7 inch	10.4 inch	15.0 inch
Type	FSTN	TFT	DSTN	TFT	TFT
Colors	2 w. Backlight	256 QVGA	256 VGA	256 VGA	32,000 XGA
Pixels	128 x 64	320 x 240	640 x 480	640 x 480	1024 x 768
Brightness	---	500 cd/m <sup>2</sup>	120 cd/m <sup>2</sup>	350 cd/m <sup>2</sup>	600 cd/m <sup>2</sup>
Backlight *	---	50,000 Hour typ.	40,000 Hour typ.	50,000 Hour typ.	50,000 Hour typ.

\* Lifetime at room temperature.

### Keypad

TS8003: 8 user legendable keys, 5 navigation keys, 12 numeric keys, 4 dedicated keys, and 3 soft keys. TS8006: 5 keys for on-screen menus. TS8008: 7 keys for on-screen menus. TS8010: 8 keys for on-screen menus. TS8015: 10 keys for on-screen menus.

### Touchscreen

Resistive Analog Type (TS8006, TS8008, TS8010, TS8015).

### Memory

**User:** 4Mb (TS8003), 8Mb (TS8006, TS8008, TS8010), or 32Mb (TS8015) onboard non-volatile flash memory.

**Memory Card:** CompactFlash Type II slot for Type I and Type II CF cards.



## Communications

**USB Port:** Adheres to USB 1.1 specification. Device only using Type B connection.

**Serial Ports:** Format and baud rates are individually programmable up to 115.2kb.

- PGM Port: RS-232 port via RJ-12.
- COMMS Ports: RS-232 port via RJ-12. RS-422/485 port via RJ-45.
- DH485 TxEn: Transmit Enable; open collector, Voh = 15vdc, Vol = 0.5vdc @ 25mA max).

**Ethernet Port:** 10/100 Base-T. RJ-45 jack is wired as a NIC.

## Environmental Conditions

**Operating Temperature Range:** 0 to 50 deg C.

**Storage Temperature Range:** -20 to 70 deg C. (TS8003, TS8006, TS8015) or 80 deg C. (TS8008, TS8010)

**Operating and Storage Humidity:** 80% maximum relative humidity (non-condensing) from 0 to 50 deg C.

**Altitude:** Up to 2000 meters.

## Certifications And Compliances

**Safety:** IEC 1010-1, EN 61010-1: Safety requirements for electrical equipment for measurement, control, and laboratory use, Part 1.

IP66 enclosure rating (face only), IEC 529.

Type 4X enclosure rating (face only), UL50.

**Electromagnetic Compatibility:** Emissions and immunity to EN 61326: Electrical equipment for measurement, control, and laboratory use, Part 1.

Immunity to industrial locations:

Electrostatic discharge	EN 61000-4-2	Criterion A
	4 kV contact xchrg, 8 kV air xchrg	
Electromagnetic RF fields	EN 61000-4-3	Criterion B
	10 V/m	
Fast transients (burst)	EN 61000-4-4	Criterion B
	2 kV power, 2 kv signal	
Surge	EN 61000-4-5	Criterion A
	1 kV L-L, 2 kV L&N-E power	

RF conducted interference EN 61000-4-6 Criterion B  
3 V/rms

Emissions:

Emissions EN 55011 Class A

**Notes:** Criterion A (normal operation within specified limits), Criterion B (temporary loss of performance from which the unit self recovers).

## Construction

Steel rear metal enclosure with NEMA 4X/IP66 aluminum front plate when correctly fitted with the provided gasket. Installation Category II, Pollution Degree 2.

## Mounting Requirements

Maximum panel thickness is 0.25 inch (6.3 mm). For NEMA 4X / IP66 sealing, a steel panel with a minimum thickness of 0.125 inch (3.17 mm) is recommended.

**Maximum Mounting Stud Torque:** 17 inch-pounds (1.92 N-m).

## Weight

TS8003: 1.96 lbs (0.89 kg). TS8006: 3.00 lbs (1.36 kg). TS8008: 3.84 lbs (1.74 kg).

TS8010: 5.53 lbs (2.51 kg). TS8015: 11.41 lbs (5.17 kg)

## Dimensions

Refer to "**Appendix A, B, C, D, and E - Dimensions**" for individual unit dimensions.

## Installation And Power

The following specifications pertain to the TS8000 series HMI. SSD Drives retains the right to modify specifications at any time, without prior notice.

### Mounting Instructions

This operator interface is designed for through-panel mounting. A panel cutout diagram and a template are provided. Care should be taken to remove any loose material from the mounting cut-out to prevent it from falling into the operator interface during installation. A gasket is provided to enable sealing to NEMA 4X/IP66 specifications. Install the provided nuts and tighten evenly for uniform gasket compression. For more Detailed documentation, refer to "**Appendix A, B, C, D, and E – Mounting Templates**".

### Connecting To Ground

This protective conductor terminal is bonded to conductive parts of the equipment for safety purposes and must be connected to an external protective grounding system.



Each TS8000 has a chassis ground terminal on the back of the unit. The unit should be connected to ground. The chassis ground is not connected to the signal common of the unit. Maintaining isolation between the ground and the signal common is not required to operate the unit, however, other equipment connected to this unit may require isolation between the ground and the signal common. *To maintain isolation between signal common and ground, care must be taken when connections are made to the unit.* For example, a power supply with isolation between its signal common and ground must be used. Also, plugging in a USB cable may connect signal common to ground.

### Power Supply Requirements

The TS8000 series requires a 24vdc power supply, rated at 9.5W (TS8003), 14W (TS8006), 24W (TS8008), 33W (TS8010) or 67W (TS8015). The units may draw considerably less than the rated power depending upon the options being used. As additional features are used, the unit will draw increasing amounts of power. Items that could cause increases are: additional communications, optional communications cards, use of the CompactFlash card, and other features programmed through DSI8000.

In any case, it is very important that the power supply is mounted correctly if the unit is to operate reliably. Please take care to observe the following points:

- The power supply must be mounted close to the unit, with usually not more than 6 feet (1.8 m) of cable between the supply and the operator interface. Ideally, the shortest length possible should be used.

- The wire used to connect the operator interface's power supply should be at least 22 gauge wire. If a longer cable run is used, a heavier gauge wire should be used. The routing of the cable should be kept away from large contactors, inverters, and other devices which may generate significant electrical noise.
- A power supply with a Class 2 or SELV rating should be used. A Class 2 or SELV power supply provides isolation to accessible circuits from hazardous voltage levels generated by a mains power supply due to single faults. SELV is an acronym for "safety extra-low voltage." SELV circuits exhibit voltage that are safe to touch both under normal operating conditions and after a single fault, such as a breakdown of a layer of basic insulation or after the failure of a single component has occurred.

## Communications

The following specifications pertain to the TS8000 series HMI. SSD Drives retains the right to modify specifications at any time, without prior notice.

### Configuring a TS8000

The TS8000 series are configured using DSI8000 software. DSI is included in the software CD that comes packaged with each unit, or is also available from SSD Drives. Updates to DSI8000 are posted on the SSD Drives website as they are made available. By configuring the TS8000 using the latest version of DSI8000, you are assured that the unit has the most up-to-date feature set. DSI software can configure the TS8000 through the RS-232 PGM port, USB port, Ethernet Port, or the CompactFlash socket.

### Cables And Drivers

The USB port is connected using a standard USB cable with a Type B connector. The driver needed to allow your PC to access the USB port will be installed along with the DSI8000 software. If this driver has not been installed, it can be downloaded from the website.

The RS-232 PGM port uses a specialized cable to connect to the serial port of your PC. If you choose to make this cable, refer to "**Appendix A, B, C, D, and E - Port Pin-Outs**" section of this document for wiring information.

### The CompactFlash Card

The CompactFlash card can also be used to program a TS8000 by placing a configuration file and firmware on the CompactFlash card. The card is then inserted into the target TS8000 and the unit is then powered on. Refer to the "**DSI8000 User Manual**" (HA471055U001) for more information on this operation.

In order to transfer data from the CompactFlash card via the USB port, a driver must be installed on your computer. This driver is installed with DSI8000 and is located in the folder: C:\Program Files\SSD Drives\DSI8000\Device\. This may have already been accomplished if the TS8000 was configured using the USB port.

### Ethernet Communications

Ethernet communications can be established at either 10 Base-T or 100 Base-T speeds. The TS8000 unit's RJ-45 jack is wired as a true NIC (network interface card). For example, when wiring to a hub or switch, use a straight-thru cable. When wiring to another NIC, however, a cross-over cable must be used.

The Ethernet connector contains two LED's. A yellow LED in the upper right corner, and a bi-color (green / amber) LED in the upper left corner. The LED's represent the following status conditions:

LED Color	Description
Yellow (solid)	Link established
Yellow (flashing)	Data transfer active
Green	10 Base-T communications
Amber	100 Base-T communications

Refer to the “**DSI8000 User Manual**” (HA471055U001) for additional information on Ethernet communications.

## RS-232 Communications

The TS8000 unit has two RS-232 ports: the PGM port, and the COMMS port. Although only one of these ports can be used for programming, both ports can be used for remote device communication. The RS-232 PGM port can be used for either master or slave protocols with any TS8000 configuration.

Examples of RS-232 communications could involve another SSD Drives product, a PLC, or a PC computer. By using a cable with RJ-12 ends on it, and a roll between Tx and Rx wires, RS-232 communications with another TS8000 series touchscreen can be established.

For RS-232 cable wiring between a TS8000 and a PC, refer to the following table:

RS-232 TS8000 To PC Connections			
TS8010: RJ-12	Name	PC: DB-9	Name
4	COM	1	DCD
5	Tx	2	Rx
2	Rx	3	Tx
	n/c	4	DTR
3	COM	5	GND
	n/c	6	DSR
1	CTS	7	RTS
6	RTS	8	CTS
	n/c	9	RI

## RS-422/485 Communications

The TS8000 has one or more RS-422/485 port, depending on the model. This port can be configured to either RS-422 or RS-485, depending upon the user's needs.

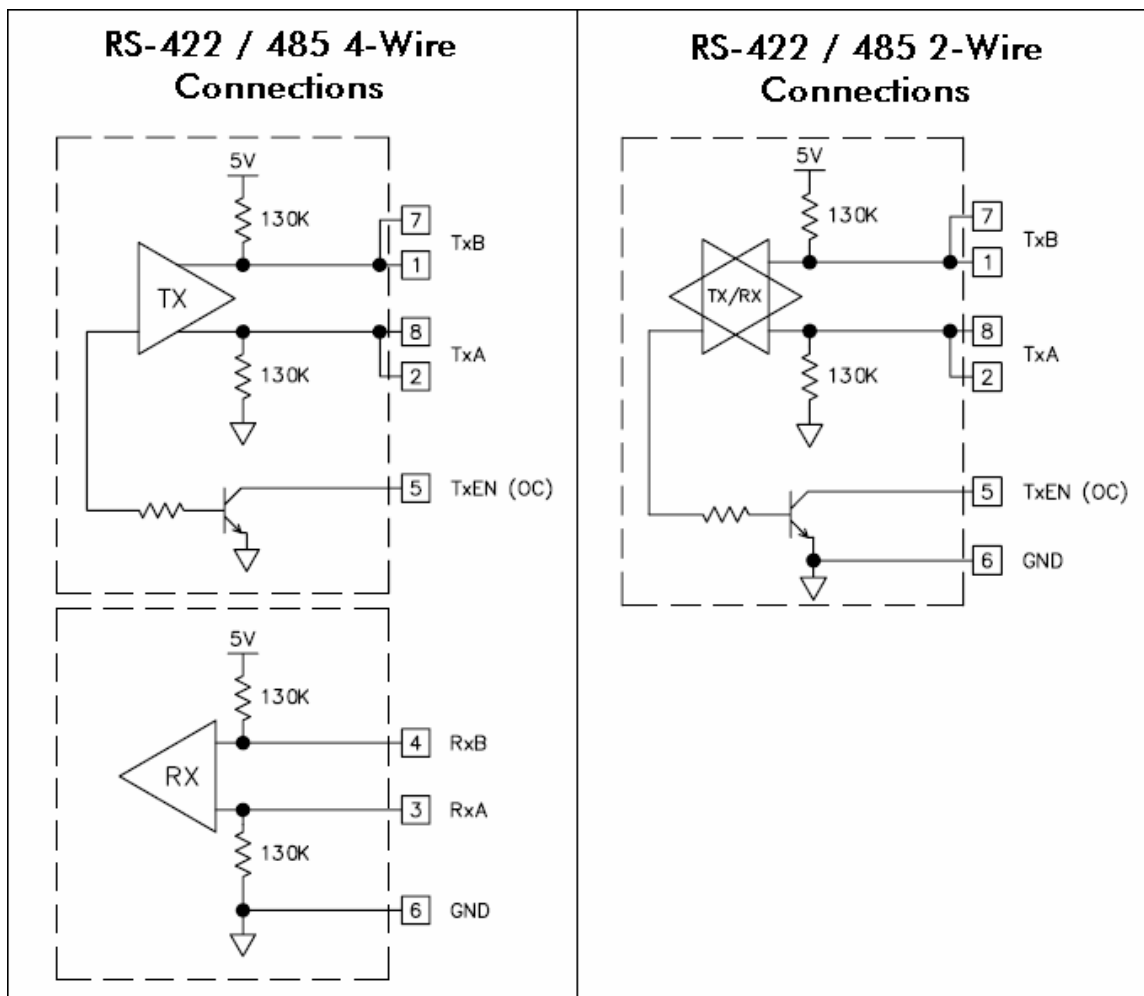

## Software / Unit Operations

The following specifications pertain to the TS8000 series HMI. SSD Drives retains the right to modify specifications at any time, without prior notice.

### DSI8000 Software

DSI8000 software is included with each purchase of a TS8000 unit, or it is also available from SSD Drives. The latest updates to the software are always available from the SSD Drives website.

### Keypad Buttons

The TS8003 keypad consist of five unique key types: eight legendable keys, 5 navigational keys, a 12 key numeric keypad, three soft keys for on screen menu selections, and four keys labeled ALARMS, MUTE, EXIT, and MENU. The TS8006 keypad consist of five user-assignable keys for on-screen menus. The TS8008 keypad consist of seven user-assignable keys for on-screen menus. The TS8010 keypad consist of eight user-assignable keys for on-screen menus. The TS8015 keypad consist of ten user-assignable keys for on-screen menus.

### Front Panel LEDs

There are three front panel LEDs. Shown below is the default status of each of the LEDs:

LED	Indication
Red LED - Power	
Flashing	Unit is in the boot loader, no valid configuration is
Steady	Unit is powered and running an application.
Yellow LED - CF Card	
Off	No CompactFlash card is present.
Steady	A valid CompactFlash card is present.
Flashing Rapidly	Unit is checking the CompactFlash card.
Flickering	Unit is writing to the CompactFlash card.
Flashing Slowly	An incorrectly formatted CompactFlash card is present.
Green LED - Alarm	
Flashing	A tag is in an alarm state.
Steady	Valid configuration loaded and no alarms are present

### Display

The TS8006, TS8008, TS8010 and TS8015 use a liquid crystal display (LCD) for displaying text and graphics. The display utilizes a cold cathode fluorescent tube



(CCFL) for lighting the display. The CCFL tubes can be dimmed for low light conditions.

These CCFL tubes have a limited lifetime. Backlight lifetime is based upon the amount of time the display is turned on at full intensity. Turning the backlight off when the display is not in use can extend the lifetime of your backlight. This can be accomplished through the DSI8000 software when configuring your unit.

## Touchscreen

The TS8006, TS8008, TS8010 and TS8015 utilize a resistive analog touchscreen for user input. The unit will only produce an audible tone (beep) when a touch on an active touchscreen cell is sensed. The touchscreen is fully functional as soon as the operator interface is initialized, and can be operated with gloved hands.

## Troubleshooting the TS8000

If for any reason you have trouble operating, connecting, or simply have questions concerning your new TS8000, contact SSD Drives technical support.

## Battery and Time Keeping

A battery is used to keep time when the unit is without power. Typical accuracy of the TS8000 time keeping is less than one minute per month drift. The state of the battery does not in any way affect the unit's program memory. All configurations are stored in non-volatile flash memory.



**Caution – Risk Of Electric Shock:** The inverter board, attached to the mounting plate, supplies the high voltage necessary to operate the backlight. Touching the inverter board may result in injury. Please exercise caution while working inside of the unit.



**Caution:** The circuit board contains static sensitive components. Before handling the operator interface without the rear cover attached, discharge static charges from your body by touching a grounded bare metal object. Ideally, handle the operator interface at a static controlled, clean workstation. Do not touch the surface areas of the circuit board. Dirt, oil, or other contaminants may adversely affect circuit operation.

To change the battery of a TS8000, remove all power and other cabling from the unit. Next, take off the unit's rear cover by removing the five screws designated by the arrows on the rear of the unit. Then, by lifting the top side, hinge the rear cover, thus providing clearance for the connectors on the bottom side of the PCB as shown in the illustration below. Remove the old battery from the holder and replace with a new one. The battery used is a CR2025 lithium button cell. Assemble in the reverse order.

The following example depicts the battery replacement procedure for a TS8010.

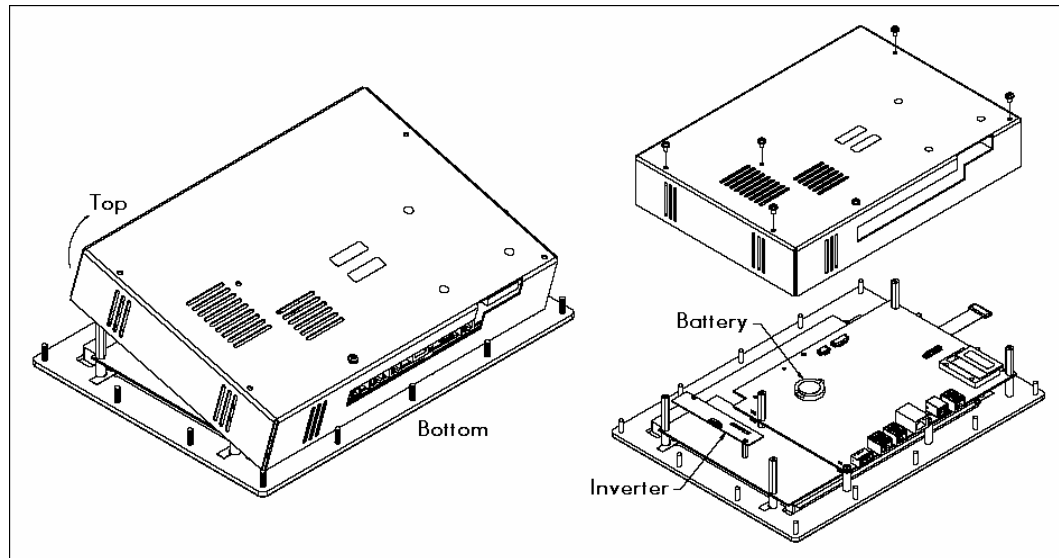

## Options And Accessories

The following specifications pertain to the TS8000 series HMI. SSD Drives retains the right to modify specifications at any time, without prior notice.

### CompactFlash Socket

The TS8000 is equipped with a Type II CompactFlash socket. This socket will accept either Type I or Type II cards. Make sure to use cards with a minimum of 4Mb capacity. Cards can be obtained at most computer and office supply retailers.

CompactFlash cards can be used for: configuration transfers, storage of larger configurations, data logging, and trend storage.

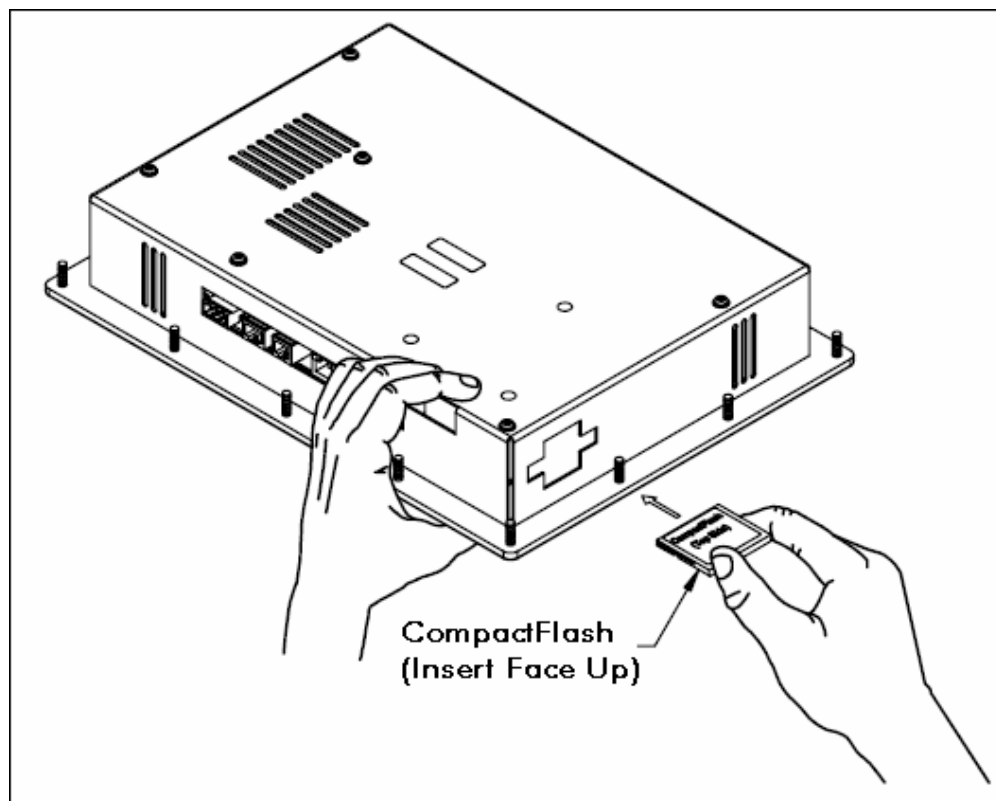

**Note:** Do not remove or insert the CompactFlash card while power is applied to the unit. Refer to the "Front Panel LEDs" section of this document for more information.

Information stored on a CompactFlash card can be read by a card reader attached to a PC. This information is stored in a Windows compatible FAT-16 file format.

### Optional Communications Cards

A communication card socket is provided for future communications cards. Visit the SSD Drives website for information and availability of these cards.

## Appendix A – TS8003 Specifications

The following specifications pertain to the TS8003 series HMI. SSD Drives retains the right to modify specifications at any time, without prior notice.

### TS8003 Dimensions

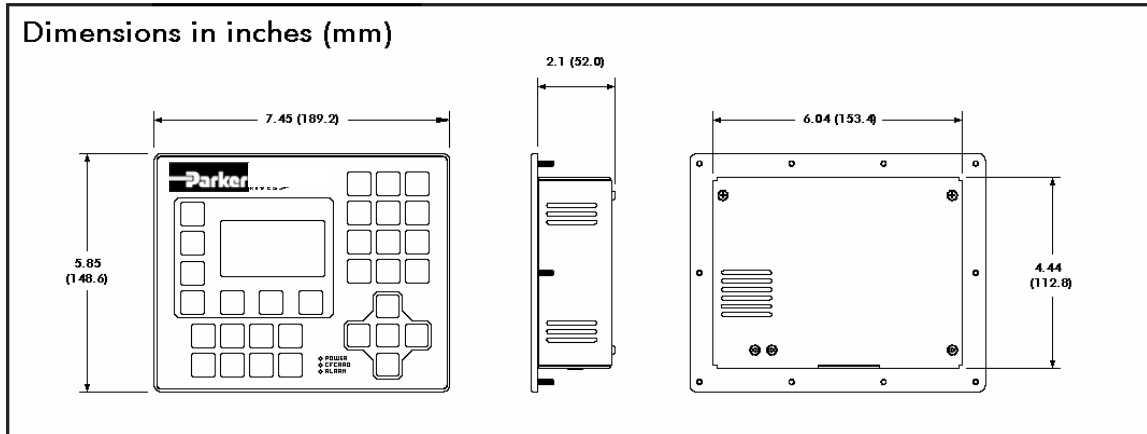

### TS8003 Mounting Specifications

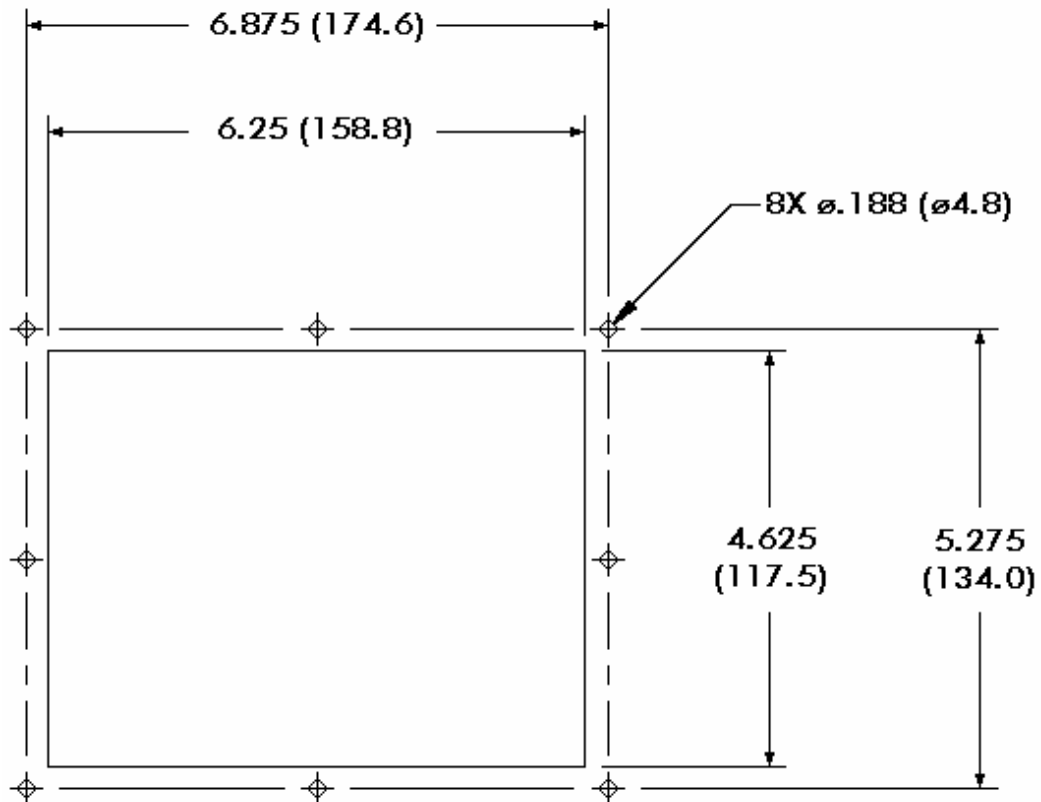

All tolerances +/- 0.010 inch (+/- .25mm)

## TS8003 Port Pin-Outs

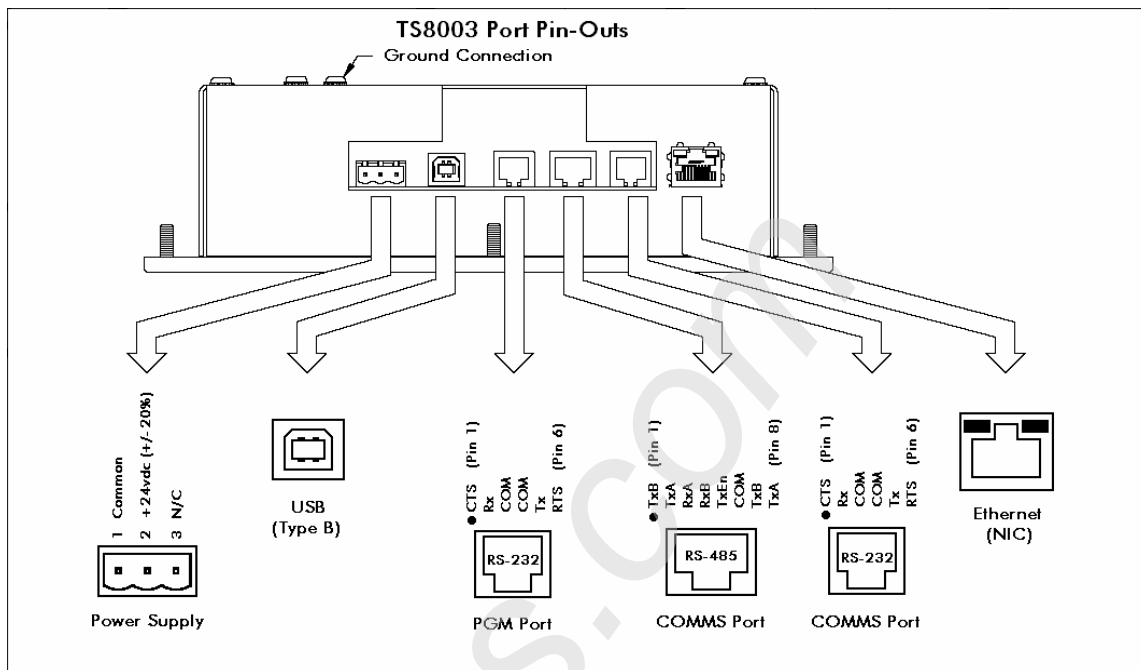

## Appendix B – TS8006 Specifications

The following specifications pertain to the TS8006 series HMI. SSD Drives retains the right to modify specifications at any time, without prior notice.

### TS8006 Dimensions

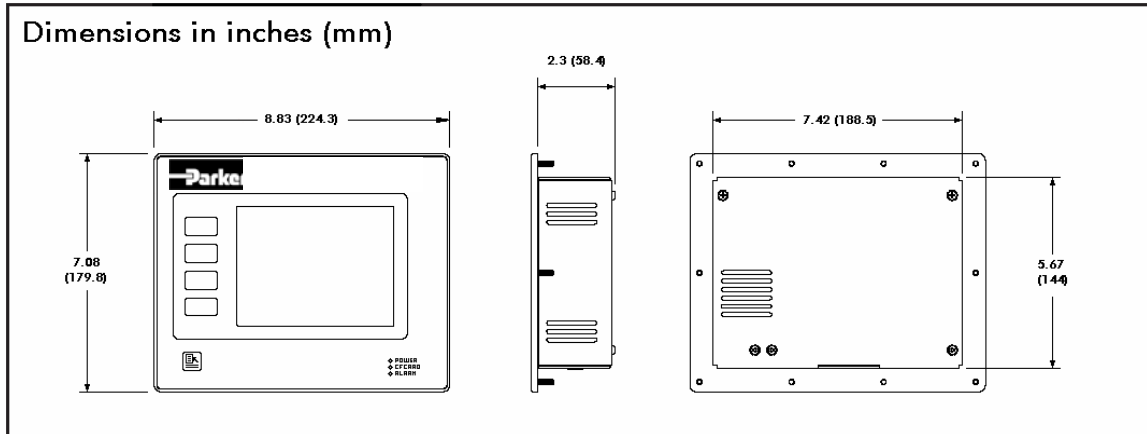

### TS8006 Mounting Specifications

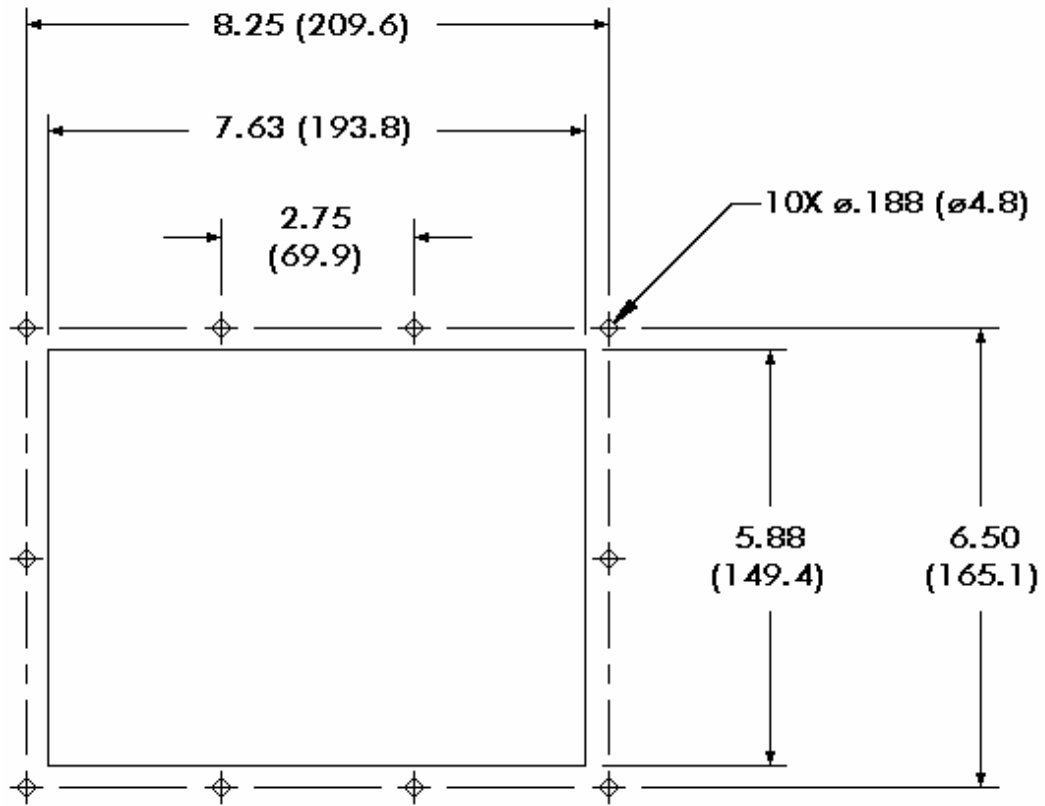

All tolerances +/- 0.010 inch (+/- .25mm)

## TS8006 Port Pin-Outs

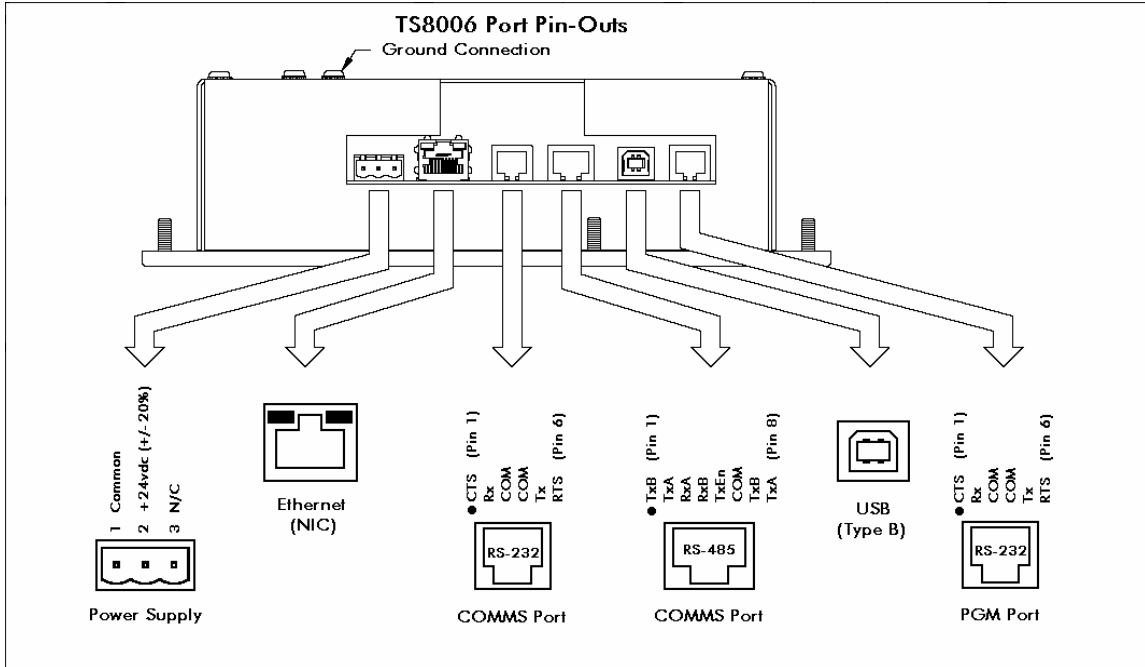

## Appendix C – TS8008 Specifications

The following specifications pertain to the TS8008 series HMI. SSD Drives retains the right to modify specifications at any time, without prior notice.

### TS8008 Dimensions

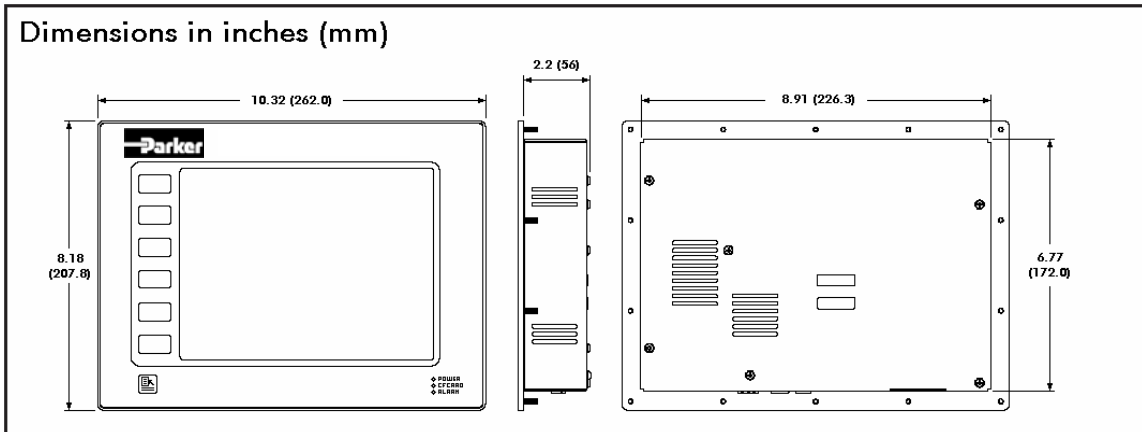

### TS8008 Mounting Specifications

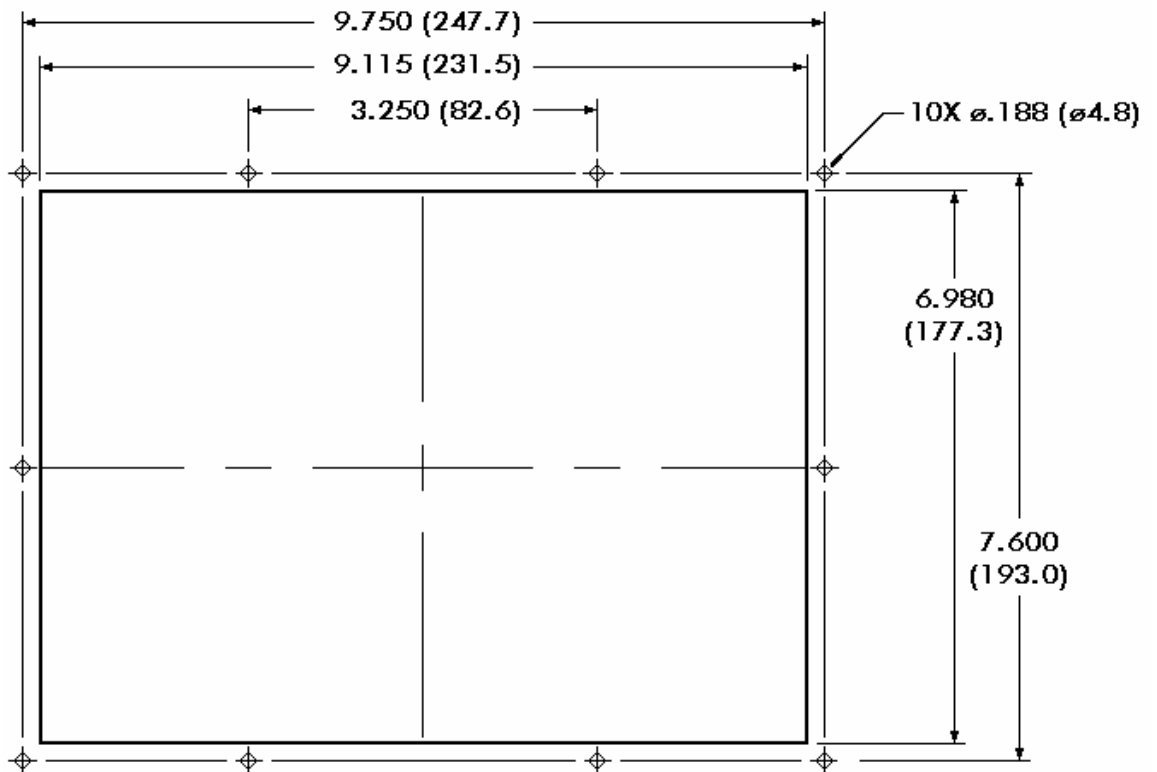

All tolerances +/- 0.010 inch (+/- .25mm)



## TS8008 Port Pin-Outs

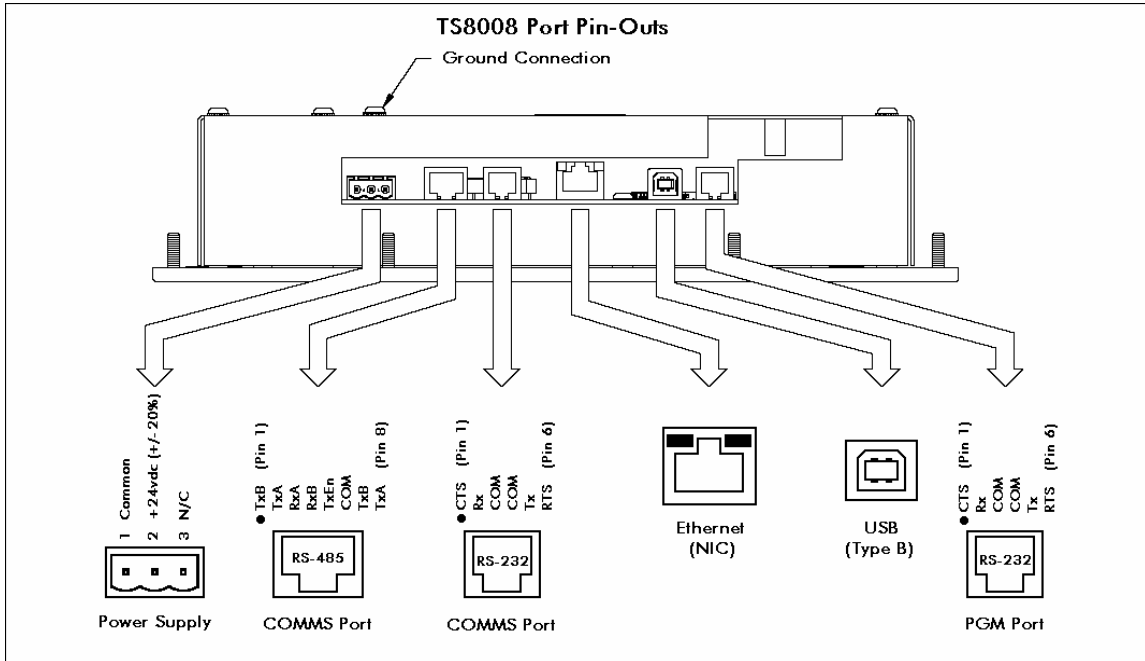

## Appendix D – TS8010 Specifications

The following specifications pertain to the TS8010 series HMI. SSD Drives retains the right to modify specifications at any time, without prior notice.

### TS8010 Dimensions

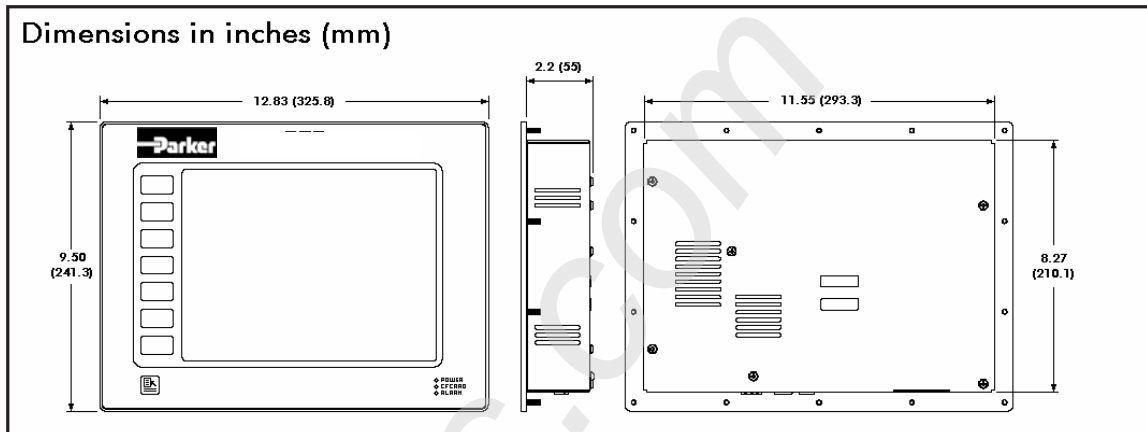

### TS8010 Mounting Specifications

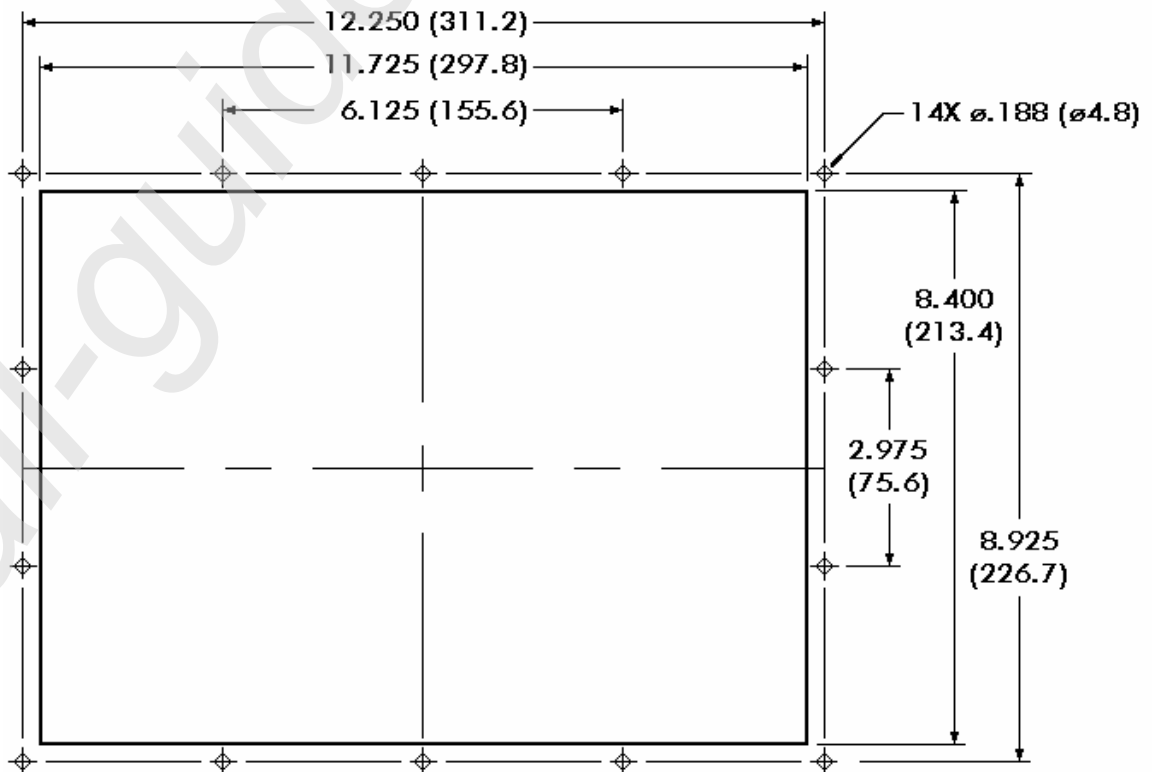

All tolerances +/- 0.010 inch (+/- .25mm)

### TS8010 Port Pin-Outs

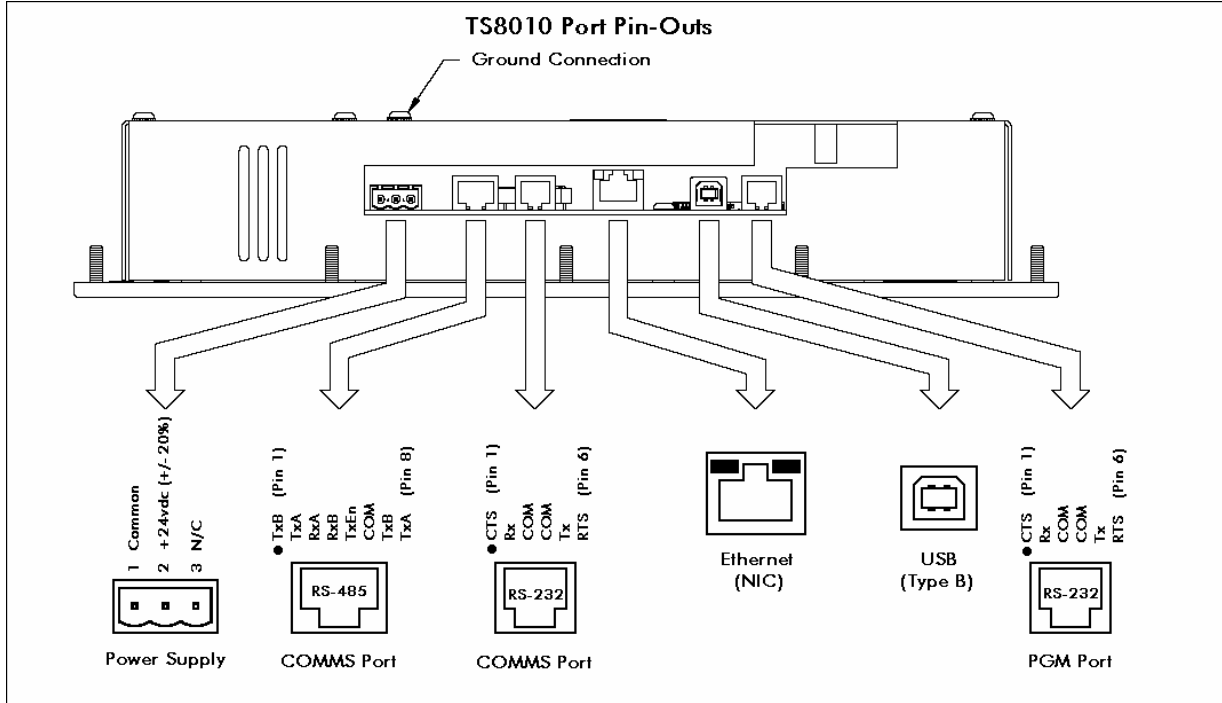

## Appendix E – TS8015 Specifications

The following specifications pertain to the TS8015 series HMI. SSD Drives retains the right to modify specifications at any time, without prior notice.

### TS8015 Dimensions

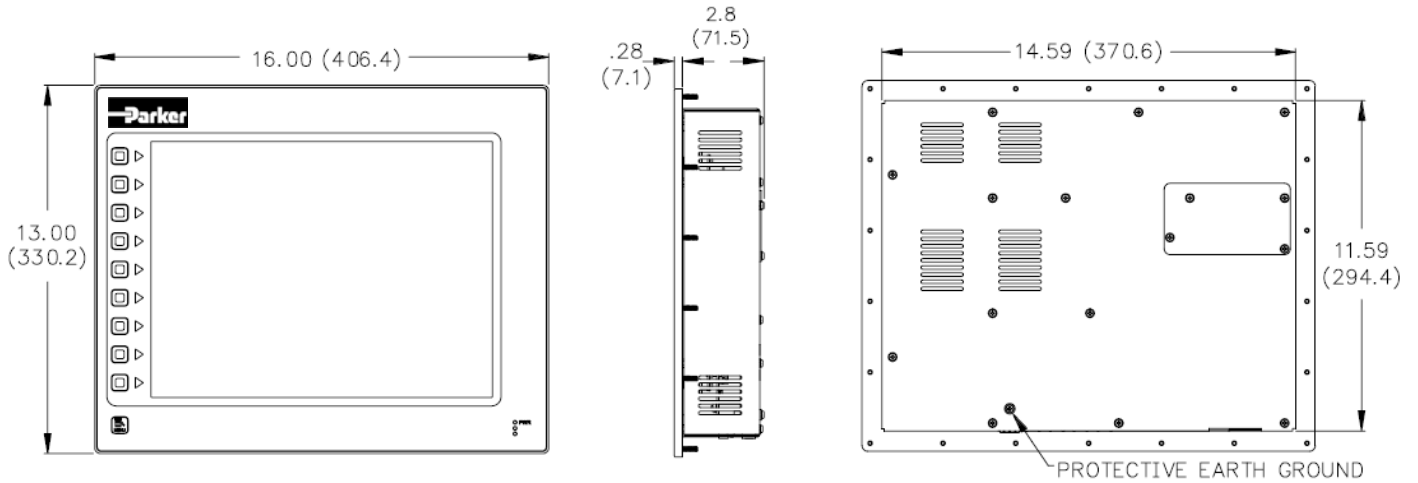

### TS8015 Mounting Specifications

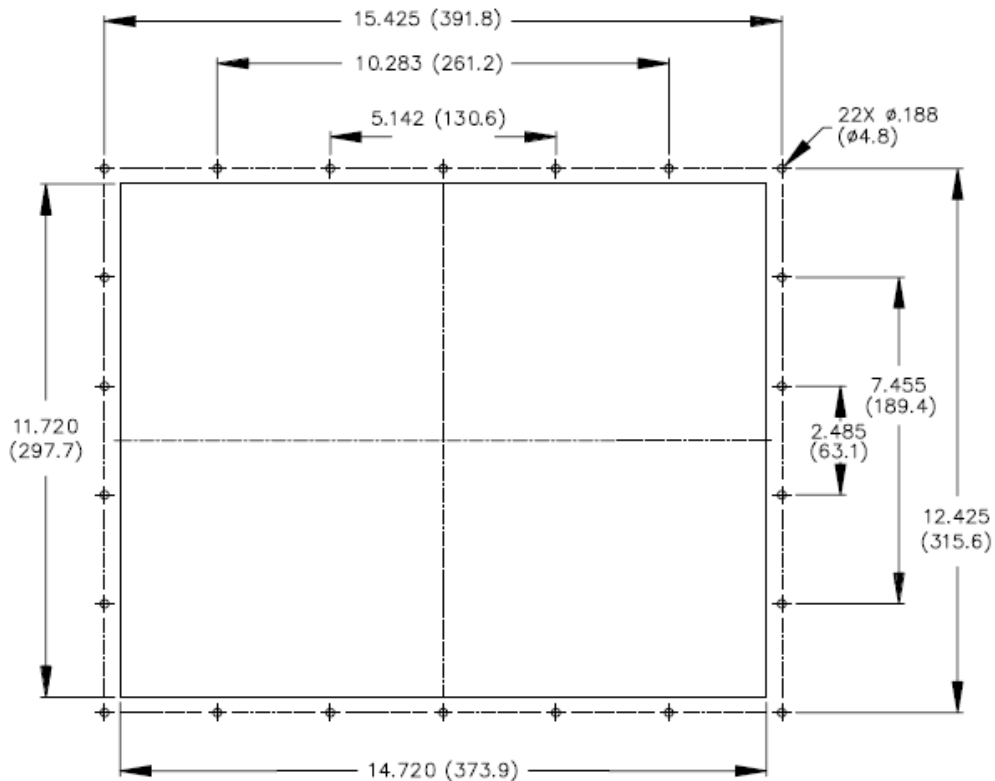

All tolerances  $\pm 0.010$ " ( $\pm 0.25$  mm).

## TS8015 Port Pin-Outs

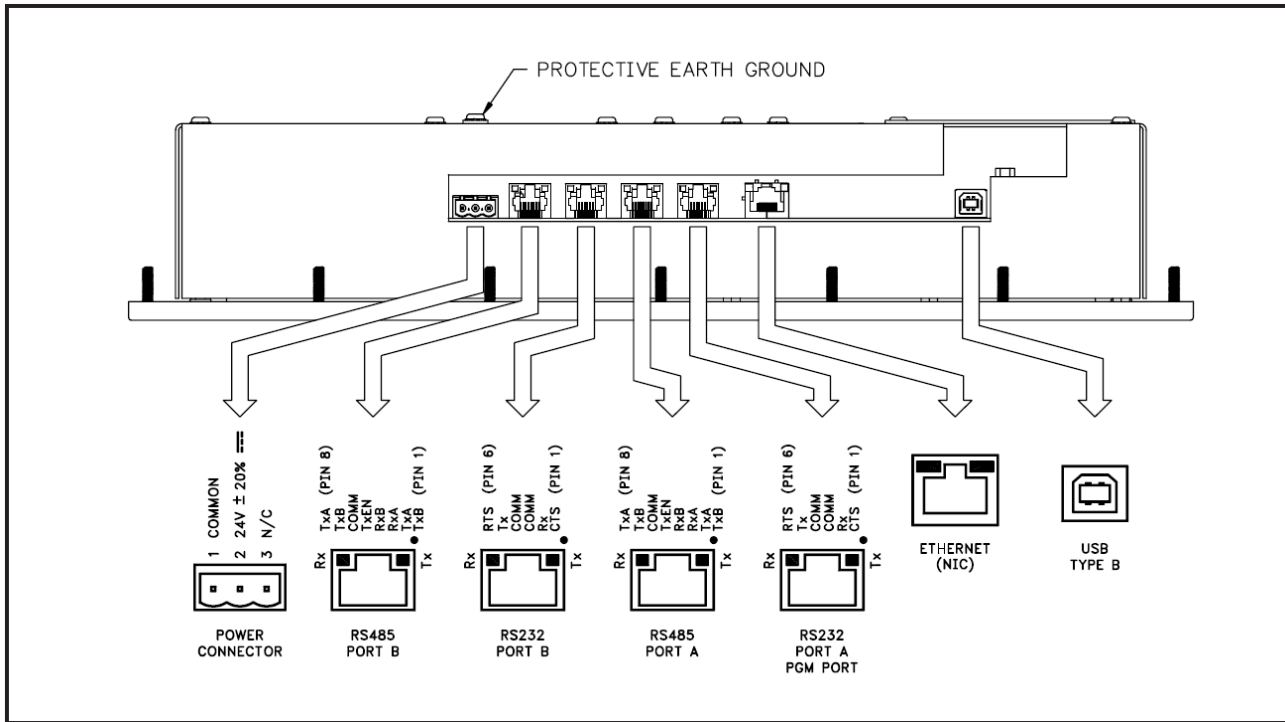

### Limited Warranty

Parker SSD Drives warrants the goods against defects in design, materials, and workmanship for the period of 12 months from the date of delivery on the terms detailed in Parker SSD Drives Standard Conditions of Sale IA058393C.

Parker SSD Drives reserves the right to change the content and product specification without notice.



[all-guides.com](http://all-guides.com)

## Sales Offices

### Australia

Parker Hannifin Pty Ltd  
9 Carrington Road  
Private Bag 4, Castle Hill  
NSW 1765  
Tel: +61 2 9634 7777  
Fax: +61 2 9899 6184

### Belgium

Parker Hannifin SA NV  
Parc Industriel Sud Zone 11  
23, Rue du Bosquet  
Nivelles B -1400  
Tel: +32 67 280 900  
Fax: +32 67 280 999

### Brazil

Parker Hannifin Ind. e Com.  
Ltda.  
Av. Lucas Nogueira Garcez,  
2181  
Esperança - Caixa Postal 148  
Tel: +55 0800 7275374  
Fax: +55 12 3954 5262

### China

Parker Hannifin Motion &  
Control  
(Shanghai) Co. Ltd. - SSD  
Drives 280 Yunqiao Road  
Export Processing Zone  
Pudong District  
Shanghai 201206 P.R. China  
Tel: +86(21)5031 2525  
Fax: +86(21)5854 7599

### Canada

Parker Motion and Control  
160 Chisolm Drive  
Milton, Ontario L9T 3G9  
Tel: +1(905)693 3000  
Fax: +1(905)876 1958

### France

Parker SSD Parvex  
8 Avenue du Lac  
B.P. 249  
F-21007 Dijon Cedex  
Tel: +33 (0)3 80 42 41 40  
Fax: +33 (0)3 80 42 41 23

### Germany

Parker Hannifin GmbH  
Von-Humboldt-Strasse 10  
64646 Heppenheim  
Tel: +49(0)6252 798200  
Fax: +49(0)6252 798205

### India

SSD Drives India Pvt Ltd  
151 Developed Plots Estate  
Perungudi,  
Chennai, 600 096  
Tel: +91 44 43910700  
Fax: +91 44 43910700

### Italy

Parker Hannifin SPA  
Via Gounod 1  
20092 Cinisello Balsamo  
Milano  
Tel: +39 02 361081  
Fax: +39 02 36108400

### Singapore

Parker Hannifin Singapore  
Pte Ltd  
11, Fourth Chin Bee Rd  
Singapore 619702  
Tel: +65 6887 6300  
Fax: +65 6265 5125

### Spain

Parker Hannifin (Espana) S.A.  
Parque Industrial Las Monjas  
Calle de las Estaciones 8  
28850 Torrejonde Ardoz  
Madrid  
Tel: +34 91 6757300  
Fax: +34 91 6757711

### Sweden

Parker Hannifin AB  
Montörgatan 7  
SE-302 60 Halmstad  
Tel: +46(35)177300  
Fax: +46(35)108407

### UK

Parker Hannifin Ltd.  
Tachbrook Park Drive  
Tachbrook Park  
Warwick  
CV34 6TU  
Tel: +44(0)1926 317970  
Fax: +44(0)1926 317980

---

[www.SSDdrives.com](http://www.SSDdrives.com)



TS8000 Getting Started



### Parker Hannifin Corporation

SSD Drives Division  
9225 Forsyth Park Dr.  
Charlotte, NC 28273  
Tel: +1 (704) 588-3246  
Fax: +1 (704) 588-3249