



Getting Started Guide

Unidrive M600

Part Number: 0478-0045-02
Issue: 2



www.controltechniques.com

Original Instructions

For the purposes of compliance with the EU Machinery Directive 2006/42/EC.

General Information

This guide covers the basic information that is required to set-up and run the drive, in applications where a drive malfunction does not result in a mechanical hazard. When the drive is used in a safety related application, i.e. where a malfunction might result in a hazard, it is essential to refer to the full user guide. The *Drive User Guide* is available for download from www.controltechniques.com/userguides.

The manufacturer accepts no liability for any consequences resulting from inappropriate, negligent or incorrect installation or adjustment of the optional operating parameters of the equipment or from mismatching the variable speed drive with the motor.

The contents of this guide are believed to be correct at the time of printing. In the interests of a commitment to a policy of continuous development and improvement, the manufacturer reserves the right to change the specification of the product or its performance, or the contents of the guide, without notice.

All rights reserved. No parts of this guide may be reproduced or transmitted in any form or by any means, electrical or mechanical including photocopying, recording or by an information storage or retrieval system, without permission in writing from the publisher.

Drive firmware version

This product is supplied with the latest firmware version. If this drive is to be connected to an existing system or machine, all drive firmware versions should be verified to confirm the same functionality as drives of the same model already present. This may also apply to drives returned from a Control Techniques Service Centre or Repair Centre. If there is any doubt please contact the supplier of the product.

The firmware version of the drive can be checked by looking at Pr **11.029**

Environmental statement

Control Techniques is committed to minimising the environmental impacts of its manufacturing operations and of its products throughout their life cycle. To this end, we operate an Environmental Management System (EMS) which is certified to the International Standard ISO 14001. Further information on the EMS, our Environmental Policy and other relevant information is available on request, or can be found at www.greendrives.com.

The electronic variable-speed drives manufactured by Control Techniques have the potential to save energy and (through increased machine/process efficiency) reduce raw material consumption and scrap throughout their long working lifetime. In typical applications, these positive environmental effects far outweigh the negative impacts of product manufacture and end-of-life disposal.

Nevertheless, when the products eventually reach the end of their useful life, they must not be discarded but should instead be recycled by a specialist recycler of electronic equipment. Recyclers will find the products easy to dismantle into their major component parts for efficient recycling. Many parts snap together and can be separated without the use of tools, while other parts are secured with conventional fasteners. Virtually all parts of the product are suitable for recycling.

Product packaging is of good quality and can be re-used. Large products are packed in wooden crates, while smaller products come in strong cardboard cartons which themselves have a high recycled fibre content. If not re-used, these containers can be recycled. Polythene, used on the protective film and bags for wrapping product, can be recycled in the same way. Control Techniques' packaging strategy prefers easily-recyclable materials of low environmental impact, and regular reviews identify opportunities for improvement.

When preparing to recycle or dispose of any product or packaging, please observe local legislation and best practice.

REACH legislation

EC Regulation 1907/2006 on the Registration, Evaluation, Authorisation and restriction of Chemicals (REACH) requires the supplier of an article to inform the recipient if it contains more than a specified proportion of any substance which is considered by the European Chemicals Agency (ECHA) to be a Substance of Very High Concern (SVHC) and is therefore listed by them as a candidate for compulsory authorisation.

For current information on how this requirement applies in relation to specific Control Techniques products, please approach your usual contact in the first instance. Control Techniques position statement can be viewed at:

<http://www.controltechniques.com/REACH>

Copyright © April 2014 Control Techniques Ltd

Issue Number: 2

Drive Firmware:01.07.01.00 onwards

Contents

1	Safety information	4
2	Product information	7
2.1	Model number	7
2.2	Nameplate description	8
2.3	Ratings	9
2.4	Drive features	13
2.5	Options / Accessories	14
3	Mechanical installation	16
3.1	Safety information	16
3.2	Fire protection	16
3.3	Mounting methods	16
3.4	Drive dimensions	17
3.5	Surface mounting	18
3.6	Terminal size and torque settings	20
3.7	Enclosure	21
3.8	EMC filters	22
4	Electrical installation	26
4.1	Supply types	27
4.2	Ratings	27
4.3	Power connections	28
4.4	Ground connections	34
4.5	Braking resistor values	35
4.6	Communications connections	36
4.7	Shield connections	36
4.8	Control connections	37
5	Getting started	38
5.1	Understanding the display	38
5.2	Keypad operation	39
5.3	Menu 0	41
5.4	Menu structure	41
5.5	Advanced menus	42
5.6	Changing the operating mode	43
5.7	Saving parameters	43
5.8	Restoring parameter defaults	44
5.9	Displaying parameters with non-default values only	44
5.10	Displaying destination parameters only	44
5.11	Parameter access level and security	44
6	Basic parameters (Menu 0)	45
6.1	Parameter descriptions	49
7	Running the motor	54
7.1	Quick start connections	54
7.2	Quick Start / start-up	59
8	NV Media Card Operation	66
8.1	Introduction	66
8.2	NV Media Card support	67
8.3	Transferring data	68
9	Further information	69
9.1	Diagnostics	69

1 Safety information

1.1 Warnings, Cautions and Notes



A Warning contains information which is essential for avoiding a safety hazard.



A Caution contains information which is necessary for avoiding a risk of damage to the product or other equipment.

NOTE

A **Note** contains information, which helps to ensure correct operation of the product.

1.2 Electrical safety - general warning

The voltages used in the drive can cause severe electrical shock and/or burns, and could be lethal. Extreme care is necessary at all times when working with or adjacent to the drive. Specific warnings are given at the relevant places in this guide.

1.3 System design and safety of personnel

The drive is intended as a component for professional incorporation into complete equipment or a system. If installed incorrectly, the drive may present a safety hazard.

The drive uses high voltages and currents, carries a high level of stored electrical energy, and is used to control equipment which can cause injury.

Close attention is required to the electrical installation and the system design to avoid hazards either in normal operation or in the event of equipment malfunction. System design, installation, commissioning/start-up and maintenance must be carried out by personnel who have the necessary training and experience. They must read this safety information and this User Guide carefully.

The STOP and SAFE TORQUE OFF functions of the drive do not isolate dangerous voltages from the output of the drive or from any external option unit. The supply must be disconnected by an approved electrical isolation device before gaining access to the electrical connections.

With the sole exception of the SAFE TORQUE OFF function, none of the drive functions must be used to ensure safety of personnel, i.e. they must not be used for safety-related functions.

Careful consideration must be given to the functions of the drive which might result in a hazard, either through their intended behavior or through incorrect operation due to a fault. In any application where a malfunction of the drive or its control system could lead to or allow damage, loss or injury, a risk analysis must be carried out, and where necessary, further measures taken to reduce the risk - for example, an over-speed protection device in case of failure of the speed control, or a fail-safe mechanical brake in case of loss of motor braking.

The SAFE TORQUE OFF function may be used in a safety-related application. The system designer is responsible for ensuring that the complete system is safe and designed correctly according to the relevant safety standards.

1.4 Environmental limits

Instructions in this guide regarding transport, storage, installation and use of the drive must be complied with, including the specified environmental limits. Drives must not be subjected to excessive physical force.

1.5 Access

Drive access must be restricted to authorized personnel only. Safety regulations which apply at the place of use must be complied with.

1.6 Fire protection

The drive enclosure is not classified as a fire enclosure. A separate fire enclosure must be provided. For further information, refer to the *Drive User Guide*.

1.7 Compliance with regulations

The installer is responsible for complying with all relevant regulations, such as national wiring regulations, accident prevention regulations and electromagnetic compatibility (EMC) regulations. Particular attention must be given to the cross-sectional areas of conductors, the selection of fuses or other protection, and protective ground (earth) connections.

This guide contains instruction for achieving compliance with specific EMC standards.

Within the European Union, all machinery in which this product is used must comply with the following directives:

2006/42/EC: Safety of machinery.

2004/108/EC: Electromagnetic Compatibility.

1.8 Motor

Ensure the motor is installed in accordance with the manufacturer's recommendations. Ensure the motor shaft is not exposed.

Standard squirrel cage induction motors are designed for single speed operation. If it is intended to use the capability of the drive to run a motor at speeds above its designed maximum, it is strongly recommended that the manufacturer is consulted first.

Low speeds may cause the motor to overheat because the cooling fan becomes less effective. The motor should be installed with a protection thermistor. If necessary, an electric forced vent fan should be used.

The values of the motor parameters set in the drive affect the protection of the motor. The default values in the drive should not be relied upon.

It is essential that the correct value is entered in Pr **00.046** motor rated current. This affects the thermal protection of the motor.

1.9 Mechanical brake control

The brake control functions are provided to allow well co-ordinated operation of an external brake with the drive. While both hardware and software are designed to high standards of quality and robustness, they are not intended for use as safety functions, i.e. where a fault or failure would result in a risk of injury. In any application where the incorrect operation of the brake release mechanism could result in injury, independent protection devices of proven integrity must also be incorporated.

1.10 Adjusting parameters

Some parameters have a profound effect on the operation of the drive. They must not be altered without careful consideration of the impact on the controlled system. Measures must be taken to prevent unwanted changes due to error or tampering.

1.11 Electrical installation

1.11.1 Electric shock risk

The voltages present in the following locations can cause severe electric shock and may be lethal:

- AC supply cables and connections
- Output cables and connections
- Many internal parts of the drive, and external option units

Unless otherwise indicated, control terminals are single insulated and must not be touched.

1.11.2 Stored charge

The drive contains capacitors that remain charged to a potentially lethal voltage after the AC supply has been disconnected. If the drive has been energized, the AC supply must be isolated at least ten minutes before work may continue.

2 Product information

This guide covers the *Unidrive M600* product.

Table 2-1 Supported operating modes

Product	Supported operating modes					
	Open-Loop	RFC-A	RFC-A Sensorless	RFC-S	RFC-S Sensorless	Regen
Unidrive M600	✓	*	✓		✓	✓

* Possible via an option module.

2.1 Model number

The way in which the model numbers for the *Unidrive M* product range is formed is illustrated below:

Figure 2-1 Model number

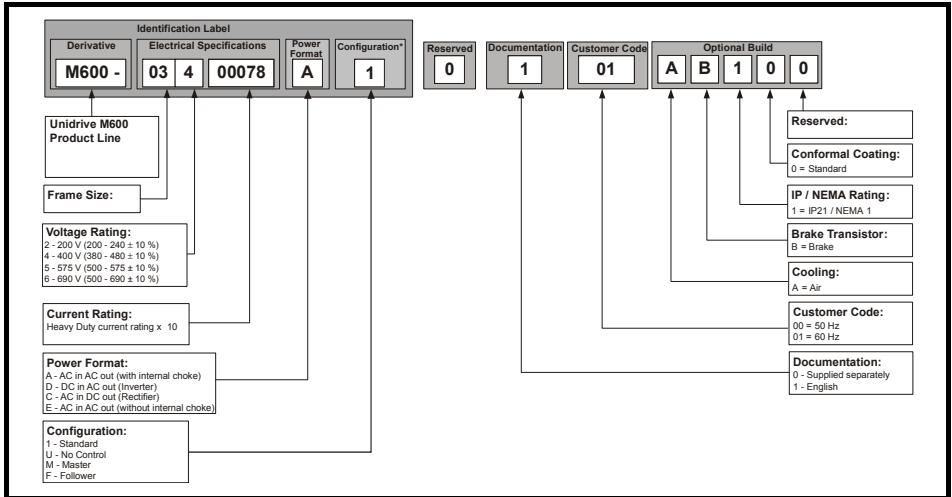

* Only shown on frame size 9E and 10 identification label.

NOTE

For simplicity a Frame 9 drive with no internal choke (i.e. Model 09xxxxxxE) is referred to as a Frame 9E and a Frame 9 drive with an internal choke (i.e. Model 09xxxxxxA) is referred to as a Frame 9A. Any reference to Frame 9 is applicable to both sizes 9E and 9A.

2.2 Nameplate description

Figure 2-2 Typical drive rating labels

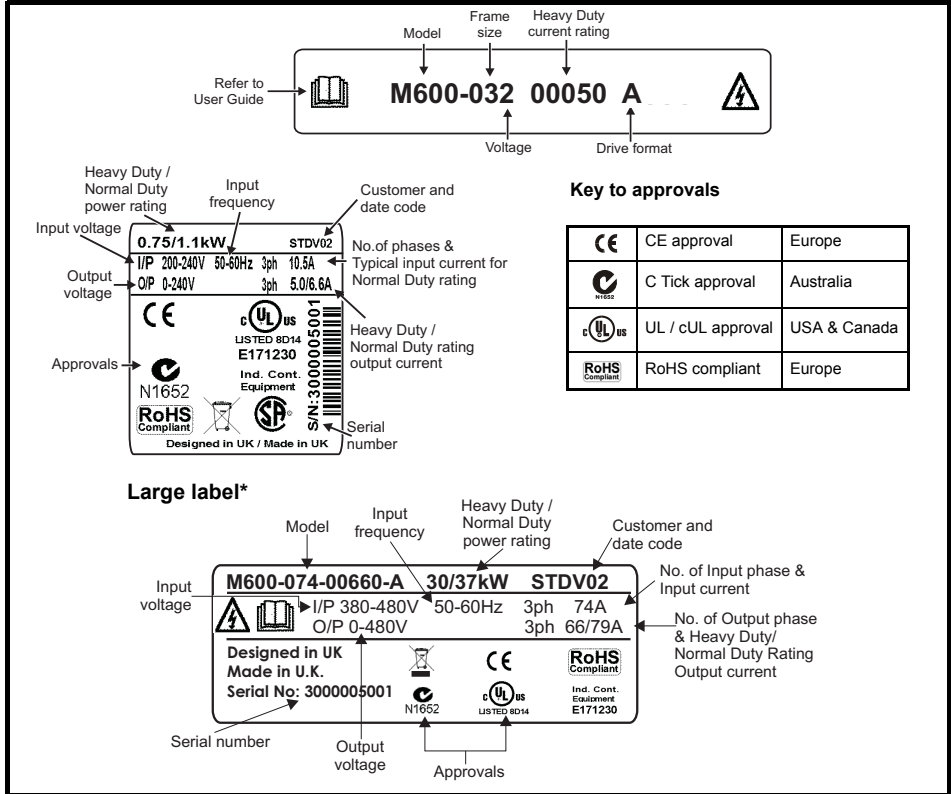

* This label is only applicable to size 7 and above.

Refer to Figure 2-1 *Model number* on page 7 for further information relating to the labels.

2.3 Ratings



Fuses

The AC supply to the drive must be installed with suitable protection against overload and short-circuits. The following section shows recommended fuse ratings. Failure to observe this requirement will cause risk of fire.

NOTE

Nominal cables sizes below are based on the cable installation method B2 (ref: IEC60364-5-52:2001) unless otherwise specified, and are provided as a guide only. Ensure cables used suit local wiring regulations.

Table 2-2 200 V drive ratings, cable sizes and fuse ratings

Model	Max. cont. input current	Fuse				Nominal cable size				Normal Duty			Heavy Duty			
		IEC		UL		European		USA		Max. cont. output current	Nom power @ 230 V	Motor power @ 230 V	Max. cont. output current	Nom power @ 230 V	Motor power @ 230 V	
		3ph	Nom	Class	Nom	Class	Input	Output	Input							Output
03200050	10.7	16		16		1.5	1.5	14	14	6.6	1.1	1.5	5	0.75	1	
03200066	13	20	gG	20	CC or J	1.5	1.5	14	14	8	1.5	2	6.6	1.1	1.5	
03200080	17.8	25		25		4	4	12	12	11	2.2	3	8	1.5	2	
03200106	20.6	25		25		4	4	12	12	12.7	3	3	10.6	2.2	3	
04200137	20.1	25	gG	25	CC or J	6	6	10	10	18	4	5	13.7	3	3	
04200185	26.8	32		30		8	8	8	8	25	5.5	7.5	18.5	4	5	
05200250	31	40	gG	40	CC or J	10	10	8	8	30	7.5	10	25	5.5	7.5	
06200330	48.8	63	gG	60	CC or J	16	16	4	4	50	11	15	33	7.5	10	
06200440	56.6	63		70		25	25	3	3	58	15	20	44	11	15	
07200610	67	80	gG	80	CC or J	35	35	2	2	75	18.5	25	61	15	20	
07200750	84	100		100		35	35	1	1	94	22	30	75	18.5	25	
07200830	105	125		125		70	70	1/0	1/0	117	30	40	83	22	30	
08201160	137	200	gR	200	HSJ	95	95	3/0	3/0	149	37	50	116	30	40	
08201320	166	200		225		2 x 70	2 x 70	2 x 1	2 x 1	180	45	60	132	37	50	
09201760	205	250	gR	250	HSJ	2 x 70 (B1)	2 x 95 (B2)	2 x 2/0		216	55	75	176	45	60	
09202190	260	315		300		2 x 95 (B1)	2 x 120 (B2)	2 x 4/0		266	75	100	219	55	75	
10202830	278	400	gR	400	HSJ	2 x 120 (B1)	2 x 120 (B2)	2 x 250		325	90	125	283	75	100	
10203000	333	450		450		2 x 150 (C)		2 x 300	2 x 250		360	110	150	300	90	125

Table 2-3 400 V drive ratings, cable sizes and fuse ratings

Model	Max. cont. input current	Fuse				Nominal cable size				Normal Duty			Heavy Duty		
		IEC		UL		European		USA		Max. cont. output current	Nom power @ 400 V	Motor power @ 460 V	Max. cont. output current	Nom power @ 400 V	Motor power @ 460 V
		3ph	Nom	Class	Nom	Class	Input	Output	Input						
		A	A		A		mm ²	mm ²	AWG	AWG	A	kW	hp	A	kW
03400025	5	6		10		1.5	1.5	18	18	3.4	1.1	1.5	2.5	0.75	1.0
03400031	6.6	10		10		1.5	1.5	16	16	4.5	1.5	2	3.1	1.1	1.5
03400045	9.1	10		10		1.5	1.5	14	14	6.2	2.2	3	4.5	1.5	2.0
03400062	13.1	20	gG	20	CC or J	2.5	2.5	14	14	7.7	3	5	6.2	2.2	3.0
03400078	13.4	20		20		2.5	2.5	14	14	10.4	4	5	7.8	3	5.0
03400100	15.8	20		20		2.5	2.5	12	12	12.3	5.5	7.5	10	4	5.0
04400150	18.7	25		25		CC or J	4	4	10	10	18.5	7.5	10	15	5.5
04400172	24.3	32	30	CC or J	6	6	8	8	24	11	15	17.2	7.5	10.0	
05400270	29	40	gG	35	CC or J	6	6	8	8	30	15	20	27	11	20
05400300		40		35		6	6	8	8	31			30	15	
06400350	36	63	gR	40	HSJ or DFJ	10	10	6	6	38	18.5	25	35	15	25
06400420	46	63		50		16	16	4	4	48	22	30	42	18.5	30
06400470	60	63		70		25	25	3	3	63	30	40	47	22	30
07400660	74	100	gG	80	CC or J	35	35	1	1	79	37	50	66	30	50
07400770	88	100		100		50	50	2	2	94	45	60	77	37	60
07401000	105	125		125		70	70	1/0	1/0	112	55	75	100	45	75
08401340	155	250	gR	225	HSJ	2 x 50	2 x 50	2 x 1	2 x 1	155	75	100	134	55	100
08401570	177	250		225		2 x 70	2 x 70	2 x 1/0	2 x 1/0	184	90	125	157	75	125
09402000	232	315	gR	300	HSJ	2 x 70 (B1)	2 x 95 (B2)	2 x 3/0	2 x 2/0	221	110	150	180	90	150
09402240	267			350		2 x 95 (B1)	2 x 120 (B2)	2 x 4/0	2 x 4/0	266	132	200	224	110	150
10402700	332	400	gR	400	HSJ	2 x 120 (C)	2 x 120 (B2)	2 x 300	2 x 250	320	160	250	270	132	200
10403200	397	450		450		2 x 150 (C)	2 x 150 (B2)	2 x 350	2 x 300	361	200	300	320	160	250

Table 2-4 575 V drive ratings, cable sizes and fuse ratings

Model	Max. cont. input current	Fuse				Nominal cable size				Normal Duty			Heavy Duty		
		IEC		UL		European		USA		Max. cont. output current	Nom power @ 575 V	Motor power @ 575 V	Max. cont. output current	Nom power @ 575 V	Motor power @ 575 V
		3ph	Nom	Class	Nom	Class	Input	Output	Input						
		A	A		A		mm ²	mm ²	AWG	AWG	A	kW	hp	A	kW
05500030	4.3	10		10		0.75	0.75	16	16	3.9	2.2	3	3	1.5	2
05500040	5.7	10	gG	10	CC or J	1	1	14	14	6.1	4	5	4	2.2	3
05500069	9.3	20		20		1.5	1.5	14	14	10	5.5	7.5	6.9	4	5
06500100	13.2	20	gG	20	CC or J	2.5	2.5	14	14	12	7.5	10	10	5.5	7.5
06500150	18.7	32		25		4	4	10	10	17	11	15	15	7.5	10
06500190	24.3	40		30		6	6	10	10	22	15	20	19	11	15
06500230	29.4	50		35		10	10	8	8	27	18.5	25	23	15	20
06500290	37.1	50		40		10	10	6	6	34	22	30	29	18.5	25
06500350	46.9	63	50	16	16	6	6	43	30	40	35	22	30		
07500440	45	50	gG	50	CC or J	16	16	4	4	53	37	50	44	30	40
07500550	62	80		80		25	25	3	3	73	45	60	55	37	50
08500630	83	125	gR	100	HSJ	35	35	1	1	86	55	75	63	45	60
08500860	104	160		150		50	50	1	1	108	75	100	86	55	75
09501040	166	150	gR	150	150	2 x 70 (B2)	2 x 35 (B2)	2 x 1	2 x 3	125	90	125	104	75	100
09501310	166	200		175	175	2 x 50 (B2)	2 x 50 (B2)	2 x 1	2 x 1	150	110	150	131	90	125
10501520	197	250	gR	250	250	2 x 70 (B2)	2 x 70 (B2)	2 x 2/0	2 x 2/0	200	130	200	152	110	150
10501900	218			250	250	2 x 95 (B2)	2 x 95 (B2)	2 x 2/0	2 x 2/0	200	150	200	190	132	200

Table 2-5 690 V drive ratings, cable sizes and fuse ratings

Model	Max. cont. input current	Fuse				Nominal cable size				Normal Duty			Heavy Duty			
		IEC		UL		European		USA		Max. cont. output current	Nom power @ 690 V	Motor power @ 690 V	Max. cont. output current	Nom power @ 690 V	Motor power @ 690 V	
		3ph	Nom	Class	Nom	Class	Input	Output	Input							Output
07600190	20	25	gG	25	CC or J	10	10	8	8	23	18.5	25	19	15	20	
07600240	26	32		30		10	10	6	6	30	22	30	24	18.5	25	
07600290	31	40		35		10	10	6	6	36	30	40	29	22	30	
07600380	39	50		50		16	16	4	4	46	37	50	38	30	40	
07600440	44	50		50		16	16	4	4	52	45	60	44	37	50	
07600540	62	80	80	25	25	3	3	73	55	75	54	45	60			
08600630	83	125	gR	100	HSJ	50	50	2	2	86	75	100	63	55	75	
08600860	104	160		150		70	70	1/0	1/0	108	90	125	86	75	100	
09601040	149	150	gR	150	HSJ	2 x 50 (B2)	2 x 35 (B2)	2 x 1	2 x 3	125	110	150	104	90	125	
09601310	171	200		200		2 x 70 (B2)	2 x 50 (B2)	2 x 1/0	2 x 1	155	132	175	131	110	150	
10601500	202	225	gR	250	HSJ	2 x 70 (B2)	2 x 70 (B2)	2 x 2/0	2 x 1/0	172	160	200	150	132	175	
10601780	225	250	aR			2 x 95 (B2)		2 x 70 (B2)	2 x 3/0	2 x 2/0	197	185	250	178	160	200

Table 2-6 Protective ground cable ratings

Input phase conductor size	Minimum ground conductor size
≤ 10 mm ²	Either 10 mm ² or two conductors of the same cross-sectional area as the input phase conductor (an additional ground connection is provided on sizes 3, 4 and 5 for this purpose).
> 10 mm ² and ≤ 16 mm ²	The same cross-sectional area as the input phase conductor
> 16 mm ² and ≤ 35 mm ²	16 mm ²
> 35 mm ²	Half of the cross-sectional area of the input phase conductor

Typical short term overload limits

The maximum percentage overload limit changes depending on the selected motor. Variations in motor rated current, motor power factor and motor leakage inductance all result in changes in the maximum possible overload. Typical values are shown in the table below:

Table 2-7 Typical overload limits

Operating mode	RFC from cold	RFC from 100 %	Open loop from cold	Open loop from 100 %
Normal Duty overload with motor rated current = drive rated current	110 % for 165 s	110 % for 9 s	110 % for 165 s	110 % for 9 s
Heavy Duty overload with motor rated current = drive rated current (size 8 and below)	200 % for 28 s	200 % for 3 s	150 % for 60 s	150 % for 7 s
Heavy Duty overload with motor rated current = drive rated current (size 9E and 10)	170 % for 42 s	170 % for 5 s	150 % for 60 s	150 % for 7 s

Generally the drive rated current is higher than the matching motor rated current allowing a higher level of overload than the default setting.

The time allowed in the overload region is proportionally reduced at very low output frequency on some drive ratings.

NOTE The maximum overload level which can be attained is independent of the speed.

Output current

The continuous output current ratings given on the rating label are for maximum 40 °C (104 °F), 1000 m altitude and 3.0 kHz switching frequency. Derating is required for higher switching frequencies, ambient temperatures >40 °C (104 °F) and higher altitude. For derating information, refer to the *Drive User Guide*.

Input current

The input current is affected by the supply voltage and impedance. The input current given on the rating label is the typical input current and is stated for a balanced supply.

Input line reactor (Frame 9E and 10)

A line reactor must be used with Frame 9E and 10. Failure to provide sufficient reactance could damage or reduce the service life of the drive. Refer to Table 2-8 below.

Table 2-8 Size 9E and 10 model and line reactor part numbers

Size	Drive model	Inductor model	Line reactor part number
9	09201760, 09202190, 09402000, 09402240	INL 401	4401-0181
		INL 401W*	4401-0208
	09501040, 09501310, 09601040, 09601310	INL 601	4401-0183
10	10202830, 10203000, 10402700, 10403200	INL 402	4401-0182
		INL 402W*	4401-0209
	10501520, 10501900, 10601500, 10601780	INL 602	4401-0184

* This may represent a more economical solution where operating temperature and cooling requirements are observed. Refer to the *Drive User Guide* for further information.

2.4 Drive features

Figure 2-3 Features of the drive (size 3 to 10)

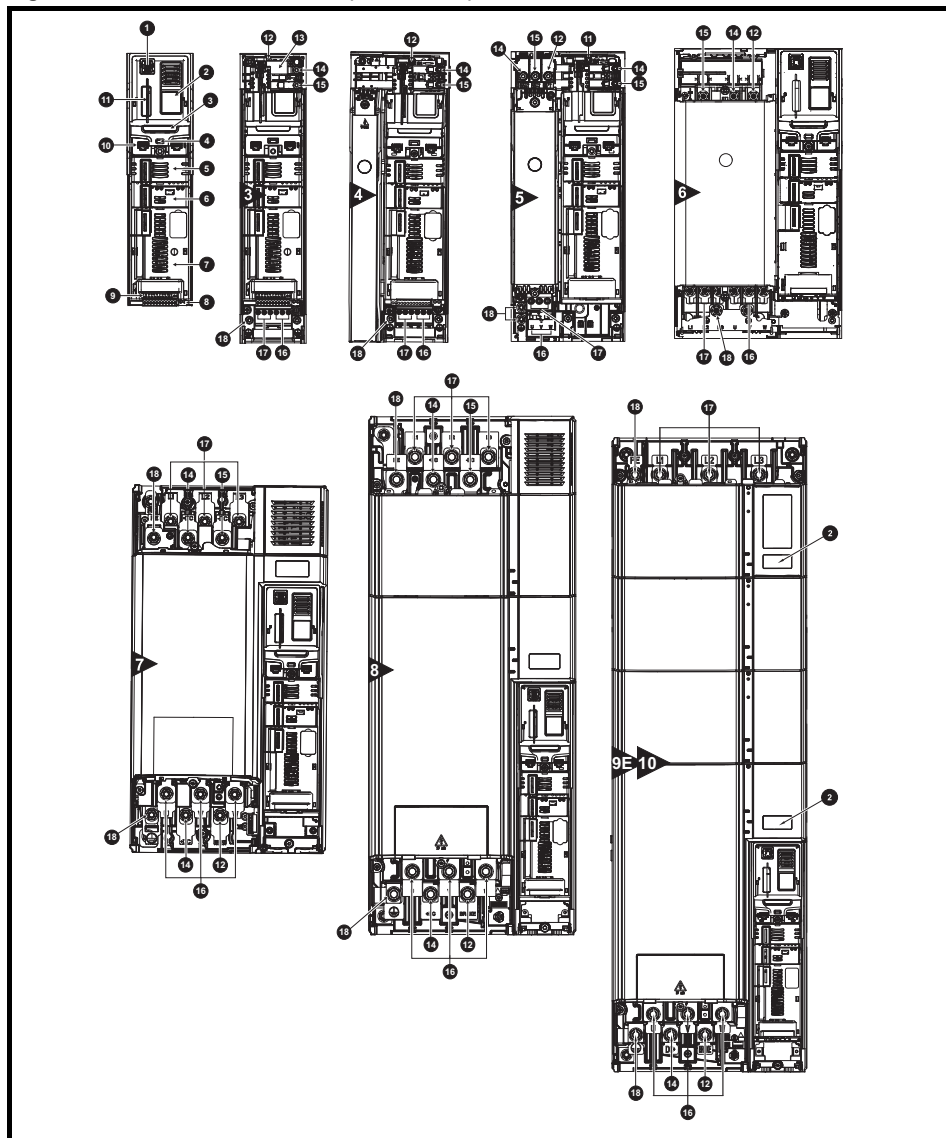

Key

- | | | | |
|-------------------------|-------------------------|-------------------------|---------------------------|
| 1. Keypad connection | 6. Option module slot 2 | 11. NV media card slot | 16. Motor connections |
| 2. Rating label | 7. Option module slot 3 | 12. Braking terminal | 17. AC supply connections |
| 3. Identification label | 8. Relay connections | 13. Internal EMC filter | 18. Ground connections |
| 4. Status LED | 9. Control connections | 14. DC bus + | |
| 5. Option module slot 1 | 10. Communications port | 15. DC bus - | |

2.5 Options / Accessories

Figure 2-4 Drive features and options

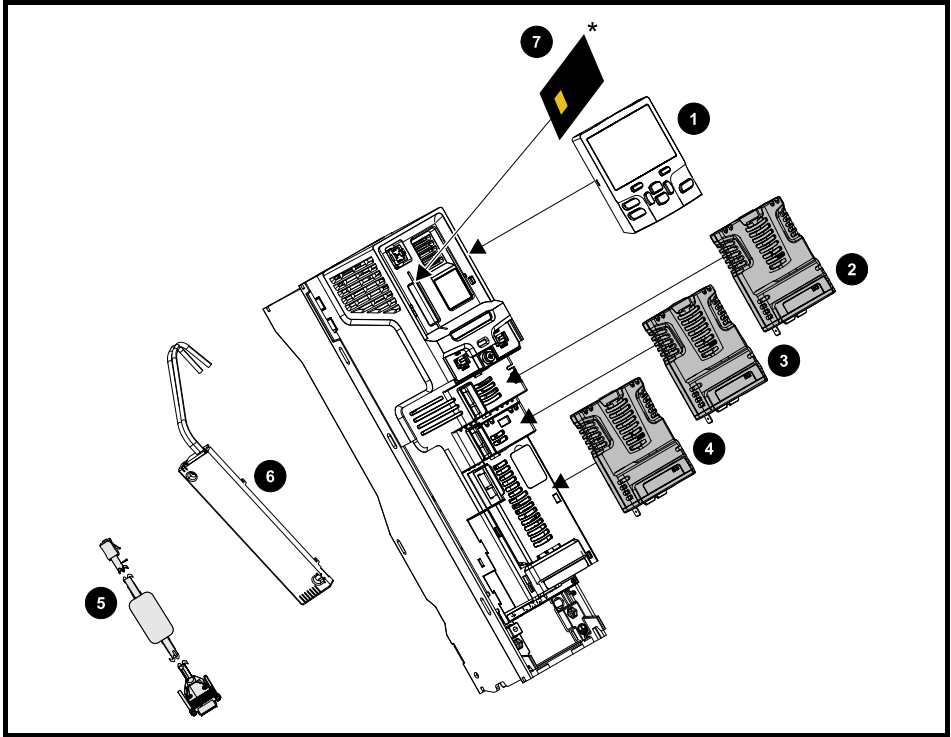

1. Keypad

2. Option module slot 1

3. Option module slot 2

4. Option module slot 3

5. CT Comms cable

6. Internal braking resistor

7. NV media card

Table 2-9 Option modules, Keypad and additional options available

Type	Name	Further details
Fieldbus	KI-485 Adaptor	485 Comms Adaptor 485 Comms adaptor provides 485 communication interface. This adaptor supports 115 k Baud, node addresses between 1 to 16 and 8 1 NP M serial mode.
	SI-PROFIBUS	Profibus option PROFIBUS adapter for communications with the drive.
	SI-DeviceNet	DeviceNet option DeviceNet adapter for communications with the drive.
	SI-CANopen	CANopen option CANopen adapter for communications with the drive.
	SI-Ethernet	Ethernet option External Ethernet module that supports EtherNet/IP and Modbus TCP/IP
	SI-PROFINET RT	PROFINET RT option PROFINET adapter for communications with the drive.
	SI-EtherCAT	EtherCAT option EtherCAT adapter for communications with the drive.
Automation (I/O expansion)	SI-I/O	Extended I/O Increases the I/O capability by adding the following combinations: Digital I/O, Digital Inputs, Analog Inputs (differential or single ended), Analog Output, Relays.
Feedback	SI-Encoder	Encoder option Incremental encoder input interface module. Provides Closed loop Rotor Flux Control for induction motors (RFC-A) on M600.
	SI-Universal Encoder	Universal Encoder option Additional combined encoder input and output interface supporting Incremental, SinCos, HIPERFACE, EnDAT and SSI encoders.
Safety	SI-Safety	Safety option Safety module that provides an intelligent, programmable solution to meet the IEC 61800-5-2 functional safety standard.
Keypad	KI-Keypad	LCD keypad option Keypad with a LCD display.
	KI-Keypad RTC	LCD keypad option Keypad with a LCD display and real time clock.
Back-up	SD Card Adaptor	SD Card Adaptor Allows the drive to use an SD card for drive back-up.
	SMARTCARD	SMARTCARD Used for parameter back-up with the drive.

For more information refer to the *Drive User Guide* and the relevant option module user guide.

2.5.1 Parts supplied with the drive

Items such as control terminals, relay connector, 24 V power supply connector, grounding bracket, surface mount brackets, grounding clamp, DC terminal cover grommets, terminal nuts, supply and motor connector and finger guard grommets are provided with the drive. For more information refer to the label on the accessory kit box supplied with the drive.

Safety information
Product information
Mechanical installation
Electrical installation
Getting started
Basic parameters
Running the motor
NV Media Card Operation
Further information

3 Mechanical installation

3.1 Safety information



Follow the instructions

The mechanical and electrical installation instructions must be adhered to. Any questions or doubt should be referred to the supplier of the equipment. It is the responsibility of the owner or user to ensure that the installation of the drive and any external option unit, and the way in which they are operated and maintained, comply with the requirements of the Health and Safety at Work Act in the United Kingdom or applicable legislation and regulations and codes of practice in the country in which the equipment is used.



Stored charge

The drive contains capacitors that remain charged to a potentially lethal voltage after the AC supply has been disconnected. If the drive has been energized, the AC supply must be isolated at least ten minutes before work may continue.

Normally, the capacitors are discharged by an internal resistor. Under certain, unusual fault conditions, it is possible that the capacitors may fail to discharge, or be prevented from being discharged by a voltage applied to the output terminals. If the drive has failed in a manner that causes the display to go blank immediately, it is possible the capacitors will not be discharged. In this case, consult Control Techniques or their authorized distributor.



Competence of the installer

The drive must be installed by professional assemblers who are familiar with the requirements for safety and EMC. The assembler is responsible for ensuring that the end product or system complies with all the relevant laws in the country where it is to be used.



Enclosure

The drive is intended to be mounted in an enclosure which prevents access except by trained and authorized personnel, and which prevents the ingress of contamination. It is designed for use in an environment classified as pollution degree 2 in accordance with IEC 60664-1. This means that only dry, non-conducting contamination is acceptable.

3.2 Fire protection

The drive enclosure is not classified as a fire enclosure. A separate fire enclosure must be provided.

For installation in the USA, a NEMA 12 enclosure is suitable.

For installation outside the USA, refer to the *Drive User Guide*.

3.3 Mounting methods

Drive sizes 3 to 7 can be either surface or through-panel mounted using the appropriate brackets.



If the drive has been used at high load levels for a period of time, the heatsink can reach temperatures in excess of 70 °C (158 °F). Human contact with the heatsink should be prevented.

3.4 Drive dimensions

Figure 3-1 Drive dimensions

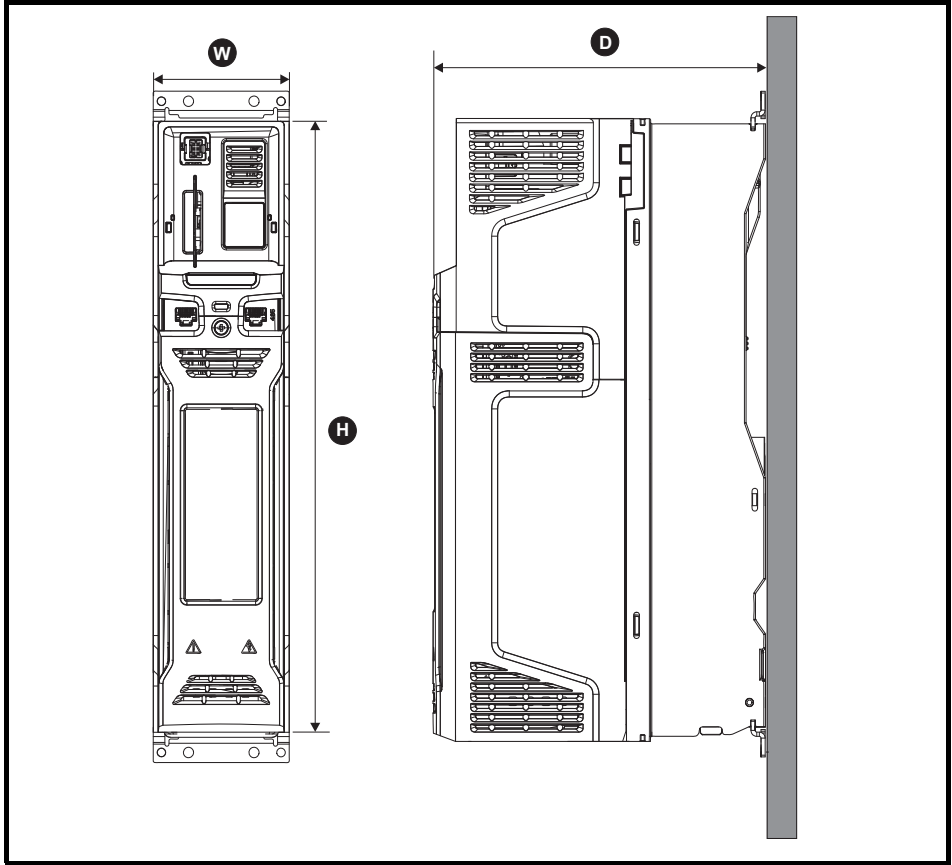

Size	H		W		D	
	mm	in	mm	in	mm	in
3	365	14.37	83	3.27	200	7.87
4			124	4.88		
5			143	5.63		
6			210	8.27		
7	508	20	270	10.63	279	11
8	753	29.65	310	12.21	290	11.42
9E and 10	1069	42.09	310	12.21	289	11.38

3.5 Surface mounting

Figure 3-2 Surface mounting dimensions (size 3 to 7)

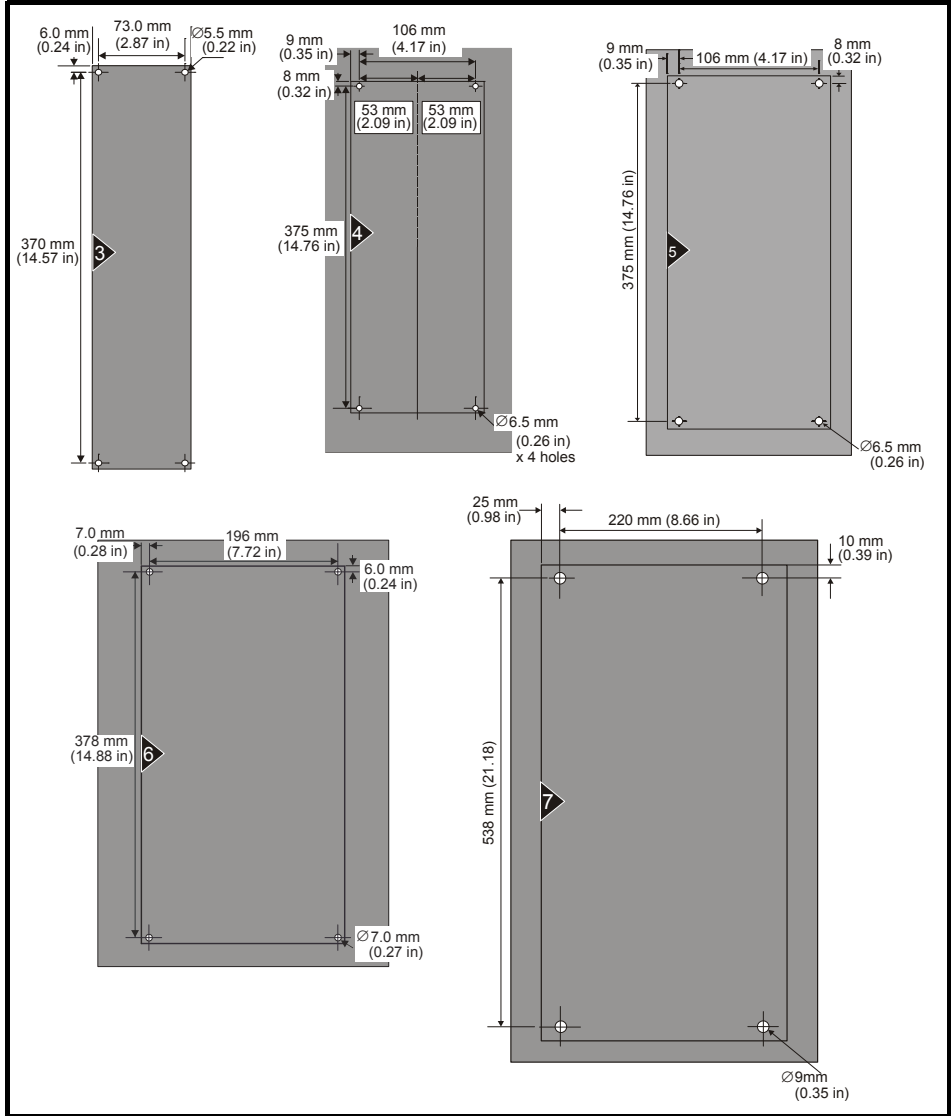
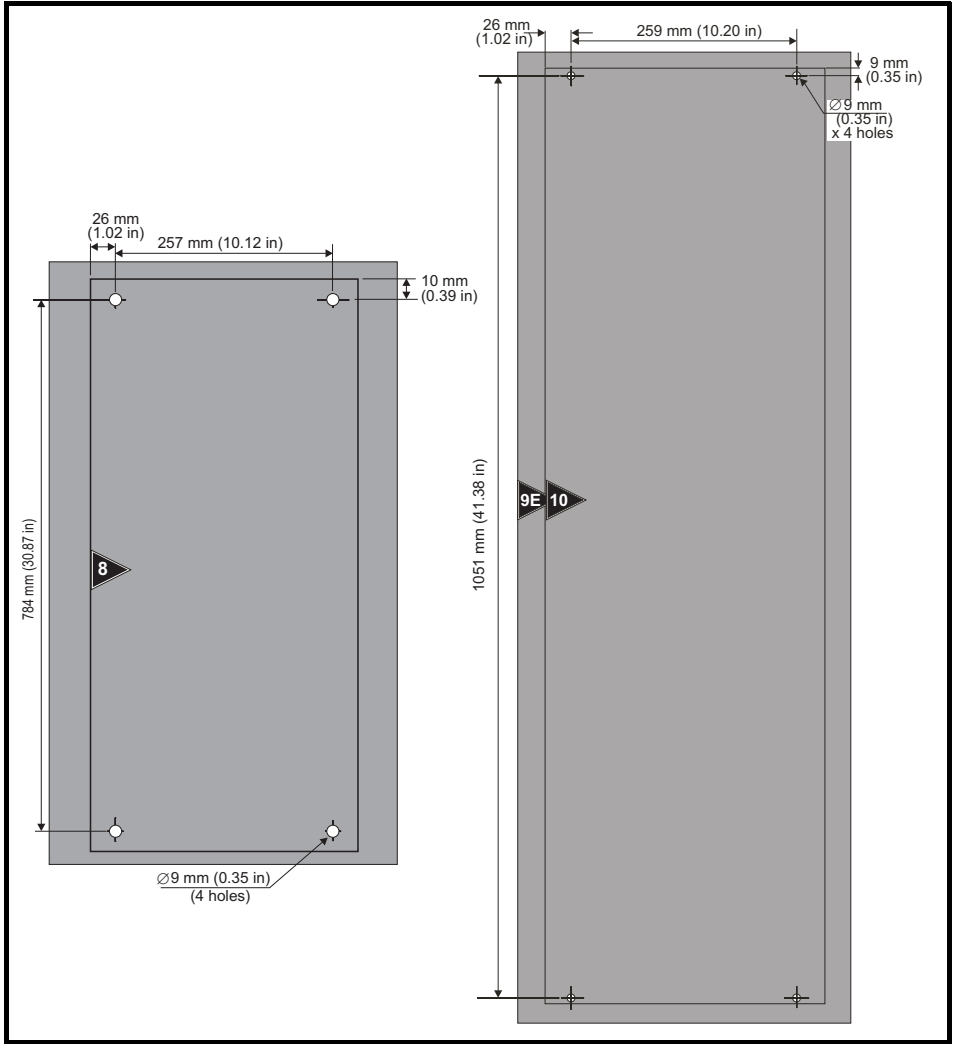

Figure 3-3 Surface mounting dimensions (size 8 to 10)



Safety information
Product information
Mechanical installation
Electrical installation
Getting started
Basic parameters
Running the motor
NV Media Card Operation
Further information

3.6 Terminal size and torque settings

Table 3-1 Drive control and relay terminal data

Model	Connection type	Torque setting
All	Plug-in terminal block	0.5 N m (0.4 lb ft)

Table 3-2 Drive power terminal data

Model size	AC terminals	DC and braking	Ground terminal
	Recommended		
3 and 4	Plug-in terminal block	T20 Torx (M4)	T20 Torx (M4) / M4 Nut (7 mm AF)
	0.7 N m (0.5 lb ft)	2.0 N m (1.47 lb ft)	2.0 N m (1.47 lb ft)
5	Plug-in terminal block 1.8 N m (1.3 lb ft)	T20 Torx (M4) / M4 Nut (7 mm AF)	M5 Nut (8 mm AF)
	1.5 N m (1.1 lb ft)	1.5 N m (1.1 lb ft)	2.0 N m (1.47 lb ft)
6		M6 Nut (10 mm AF)	
		6.0 N m (4.42 lb ft)	
7		M8 Nut (13 mm AF)	
		12.0 N m (8.85 lb ft)	
8 to 10		M10 Nut (17 mm AF)	
		15.0 N m (11.1 lb ft)	

3.7 Enclosure

Enclosure Layout

Please observe the clearances in the diagram below taking into account any appropriate notes for other devices / auxiliary equipment when planning the installation.

Figure 3-4 Enclosure layout

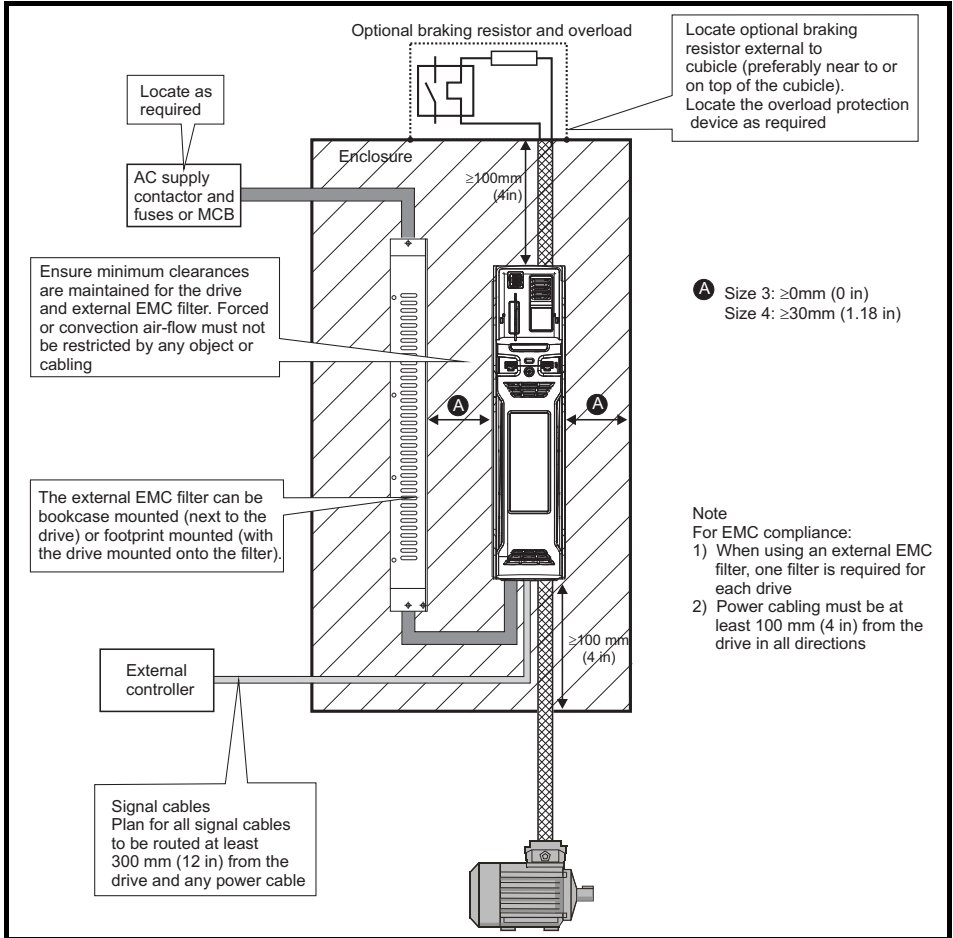

3.8 EMC filters

3.8.1 Internal filter

It is recommended that the internal EMC filter be kept in place unless there is a specific reason for removing it. If the drive is part of a regen system or it is connected to an IT supply then the internal EMC filter must be removed. The internal EMC filter reduces radio-frequency emission into the line power supply. Where the motor cable is short, it permits the requirements of EN 61800-3:2004 to be met for the second environment - for further information see the *Drive User Guide*. For longer motor cables the filter continues to provide a useful reduction in emission level, and when used with any length of shielded motor cable up to the limit for the drive, it is unlikely that nearby industrial equipment will be disturbed. It is recommended that the filter be used in all applications unless the instructions given above require it to be removed or the ground leakage current of the drive is unacceptable.

Figure 3-5 Removal of Size 3 internal EMC filter

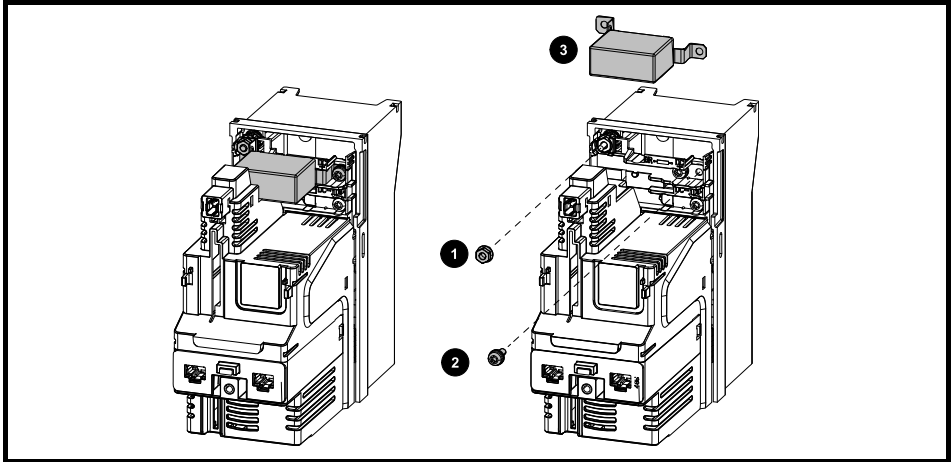

Loosen / remove the screw and nut as shown (1) and (2).

Lift away from securing points and then rotate away from the drive. Ensure the screw and nut are replaced and re-tightened with a maximum torque of 2 N m (1.47 lb ft).

Figure 3-6 Removal of the size 4 internal EMC filter

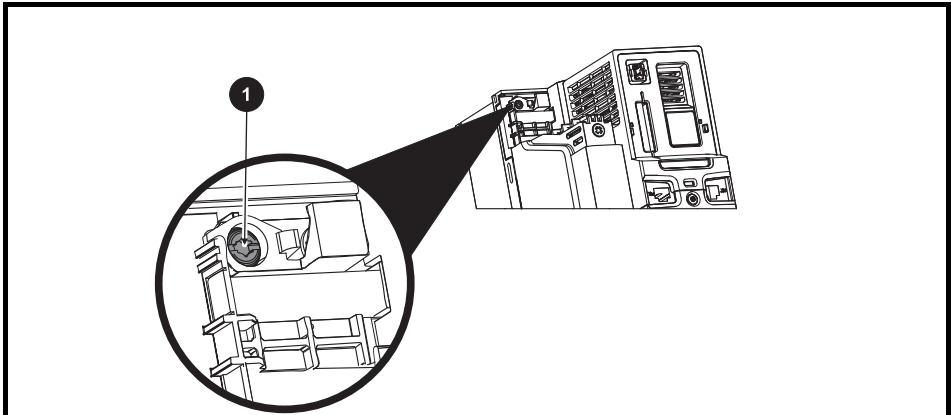

To electrically disconnect the Internal EMC filter, remove the screw (1) as highlighted above.

Figure 3-7 Removal of the size 5 internal EMC filter

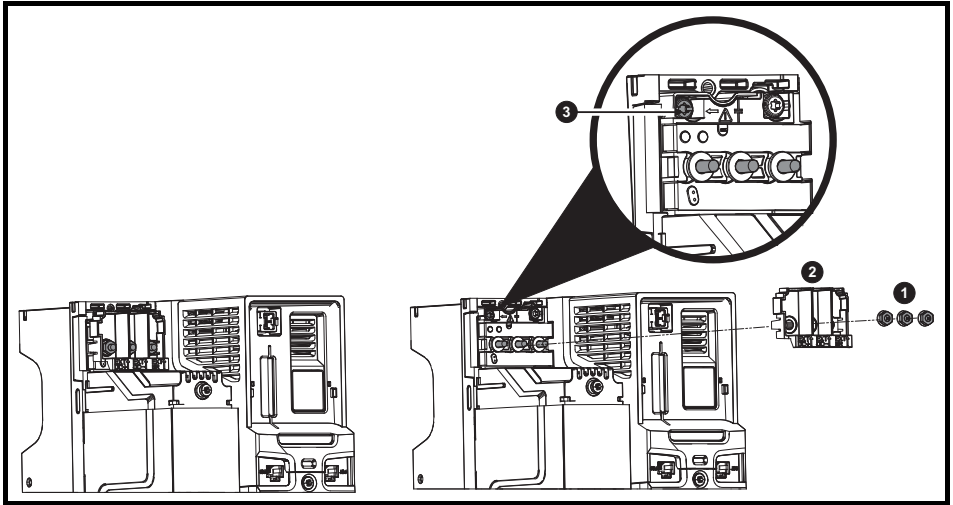

Remove the three M5 terminal nuts (1). Lift away the cover (2) to expose the M4 Torx internal EMC filter removal screw. Finally remove the M4 Torx internal EMC filter removal screw (3) to electrically disconnect the internal EMC filter.

Figure 3-8 Removal of the size 6 internal EMC filter

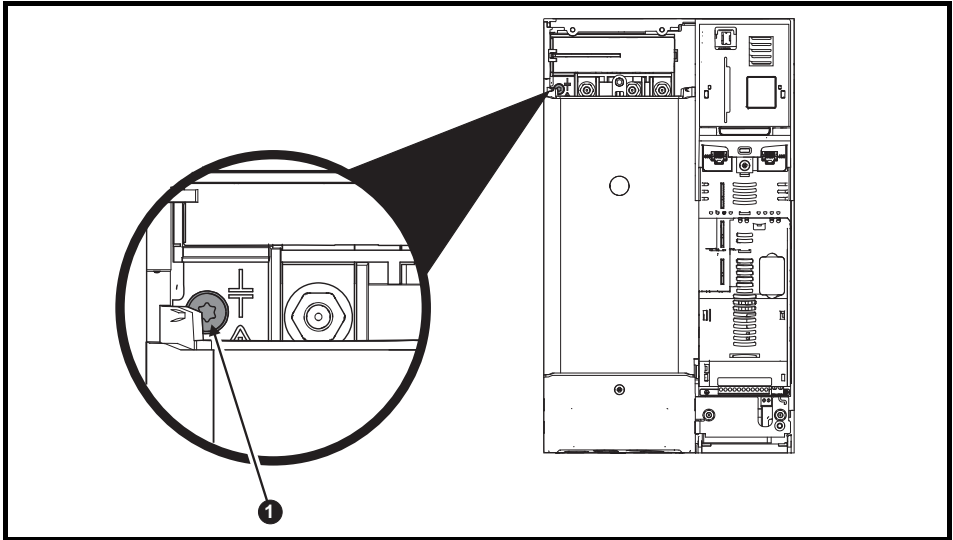

To electrically disconnect the Internal EMC filter, remove the screw (1) as highlighted above.

Figure 3-9 Removal of the size 7 and 8 internal EMC filter and line to ground varistors (size 7 shown)

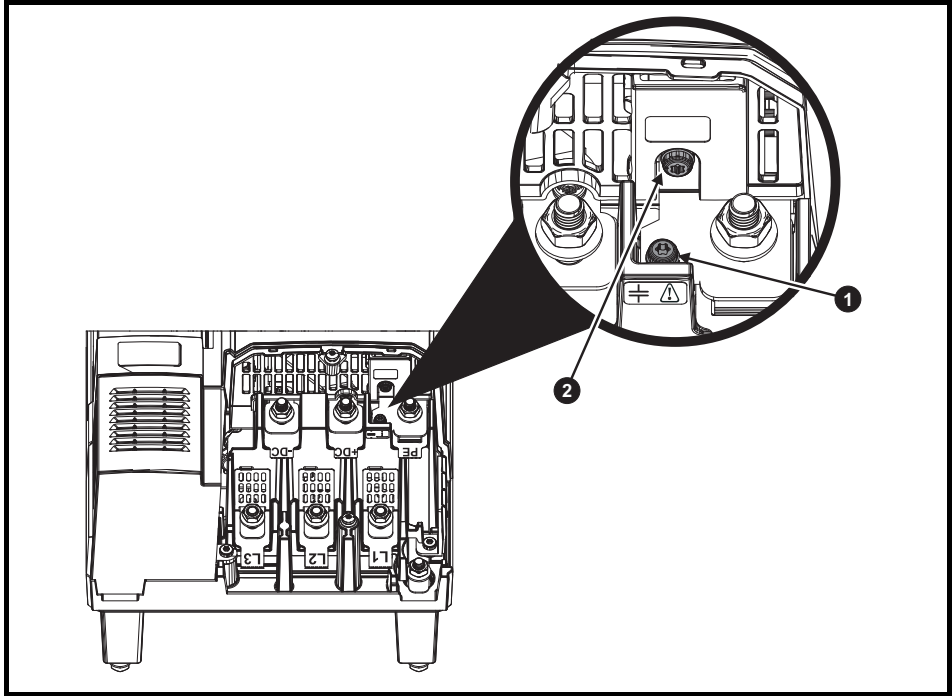

To electrically disconnect the Internal EMC filter, remove the screw as highlighted above (1).

To electrically disconnect the line to ground varistors, remove the screw as highlighted above (2).

NOTE

The line to ground varistors should only be removed in special circumstances such as ungrounded supplies with more than one source, for example on ships. Contact the supplier of the drive for more information.

Figure 3-10 Removal of size 9E and 10 line to ground varistors

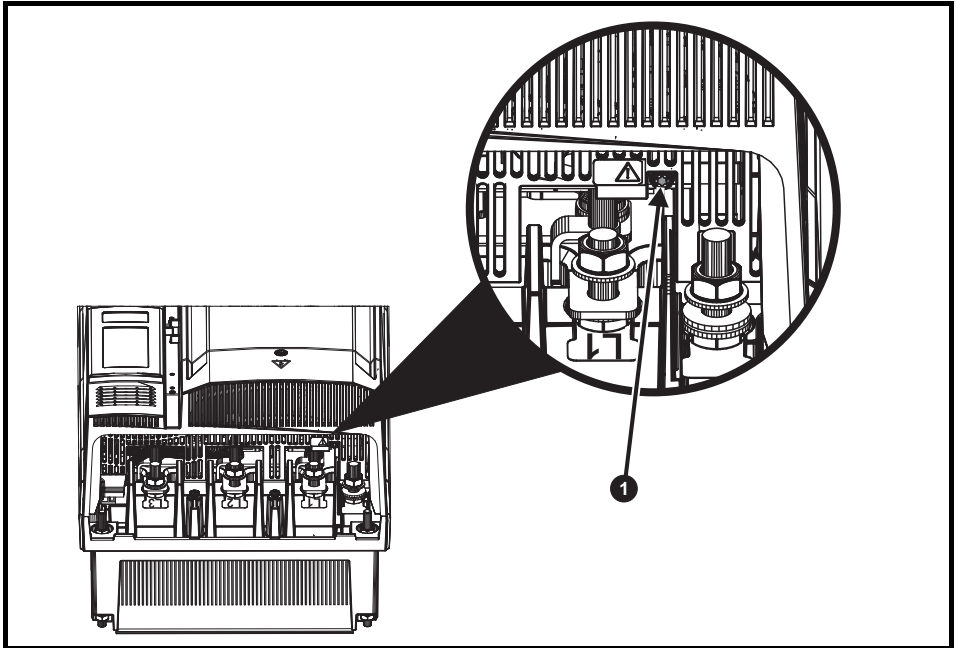

To electrically disconnect the line to ground varistors, remove the screw as highlighted above (1).

NOTE

The Internal EMC filter on size 9E and 10 cannot be removed.

NOTE

The line to ground varistors should only be removed in special circumstances such as ungrounded supplies with more than one source, for example on ships. Contact the supplier of the drive for more information.

3.8.2 External filter

The external EMC filter for size 3, 4, 5 and 6 can be footprint or bookcase mounted.

For information on drive and EMC filter cross reference, refer to the *Drive User Guide*.



To avoid a fire hazard and maintain validity of the UL listing, adhere to the specified tightening torques for the power and ground terminals.

For further information refer to the *Drive User Guide*.

4 Electrical installation



Electric shock risk

The voltages present in the following locations can cause severe electric shock and may be lethal:

AC supply cables and connections

DC and brake cables, and connections

Output cables and connections

Many internal parts of the drive, and external option units

Unless otherwise indicated, control terminals are single insulated and must not be touched.



Isolation device

The AC and / or DC power supply must be disconnected from the drive using an approved isolation device before any cover is removed from the drive or before any servicing work is performed.



STOP function

The STOP function does not remove dangerous voltages from the drive, the motor or any external option units.



SAFE TORQUE OFF function

The SAFE TORQUE OFF function does not remove dangerous voltages from the drive, the motor or any external option units.



Stored charge

The drive contains capacitors that remain charged to a potentially lethal voltage after the AC and / or DC power supply has been disconnected. If the drive has been energized, the AC and / or DC power supply must be isolated at least ten minutes before work may continue. Normally, the capacitors are discharged by an internal resistor. Under certain, unusual fault conditions, it is possible that the capacitors may fail to discharge, or be prevented from being discharged by a voltage applied to the output terminals. If the drive has failed in a manner that causes the display to go blank immediately, it is possible the capacitors will not be discharged. In this case, consult Control Techniques or their authorized distributor.



Equipment supplied by plug and socket

Special attention must be given if the drive is installed in equipment which is connected to the AC supply by a plug and socket. The AC supply terminals of the drive are connected to the internal capacitors through rectifier diodes which are not intended to give safety isolation. If the plug terminals can be touched when the plug is disconnected from the socket, a means of automatically isolating the plug from the drive must be used (e.g. a latching relay).



Permanent magnet motors

Permanent magnet motors generate electrical power if they are rotated, even when the supply to the drive is disconnected. If that happens then the drive will become energized through its motor terminals. If the motor load is capable of rotating the motor when the supply is disconnected, then the motor must be isolated from the drive before gaining access to any live parts.

4.1 Supply types

All drives are suitable for use on any supply type i.e TN-S, TN-C-S, TT and IT.

Supplies with voltage up to 600 V may have grounding at any potential, i.e. neutral, centre or corner ("grounded delta")

Supplies with voltage above 600 V may not have corner grounding

Drives are suitable for use on supplies of installation category III and lower, according to IEC 60664-1. This means they may be connected permanently to the supply at its origin in a building, but for outdoor installation additional over-voltage suppression (transient voltage surge suppression) must be provided to reduce category IV to category III.

NOTE If the drive is to be used on an IT (ungrounded) supply, refer to the *Drive User Guide* for more information.

4.2 Ratings

See section 2.3 *Ratings* on page 9.

Maximum continuous input current

The values of maximum continuous input current are given to aid the selection of cables and fuses. These values are stated for the worst case condition with the unusual combination of stiff supply with high imbalance. The value stated for the maximum continuous input current would only be seen in one of the input phases. The current in the other two phases would be significantly lower.

The values of maximum input current are stated for a supply with a 2 % negative phase-sequence imbalance and rated at the maximum supply fault current given in section 2.3 *Ratings* on page 9.

The nominal cable sizes given in section 2.3 *Ratings* on page 9 are only a guide. Refer to local wiring regulations for the correct size of cables. In some cases a larger cable is required to avoid excessive voltage drop.

NOTE The nominal output cable sizes in section 2.3 *Ratings* on page 9 assume that the motor maximum current matches that of the drive. Where a motor of reduced rating is used the cable rating may be chosen to match that of the motor. To ensure that the motor and cable are protected against over-load, the drive must be programmed with the correct motor rated current.



Fuses

The AC supply to the drive must be installed with suitable protection against overload and short-circuits. Nominal fuse ratings are shown in section 2.3 *Ratings* on page 9. Failure to observe this requirement will cause risk of fire.

A fuse or other protection must be included in all live connections to the AC supply.

An MCB (miniature circuit breaker) or MCCB (moulded-case circuit-breaker) with type C may be used in place of fuses for size 3 under the following conditions:

- The fault-clearing capacity must be sufficient for the installation

Fuse types

The fuse voltage rating must be suitable for the drive supply voltage.

4.3 Power connections

Figure 4-1 Size 3 power and ground connections

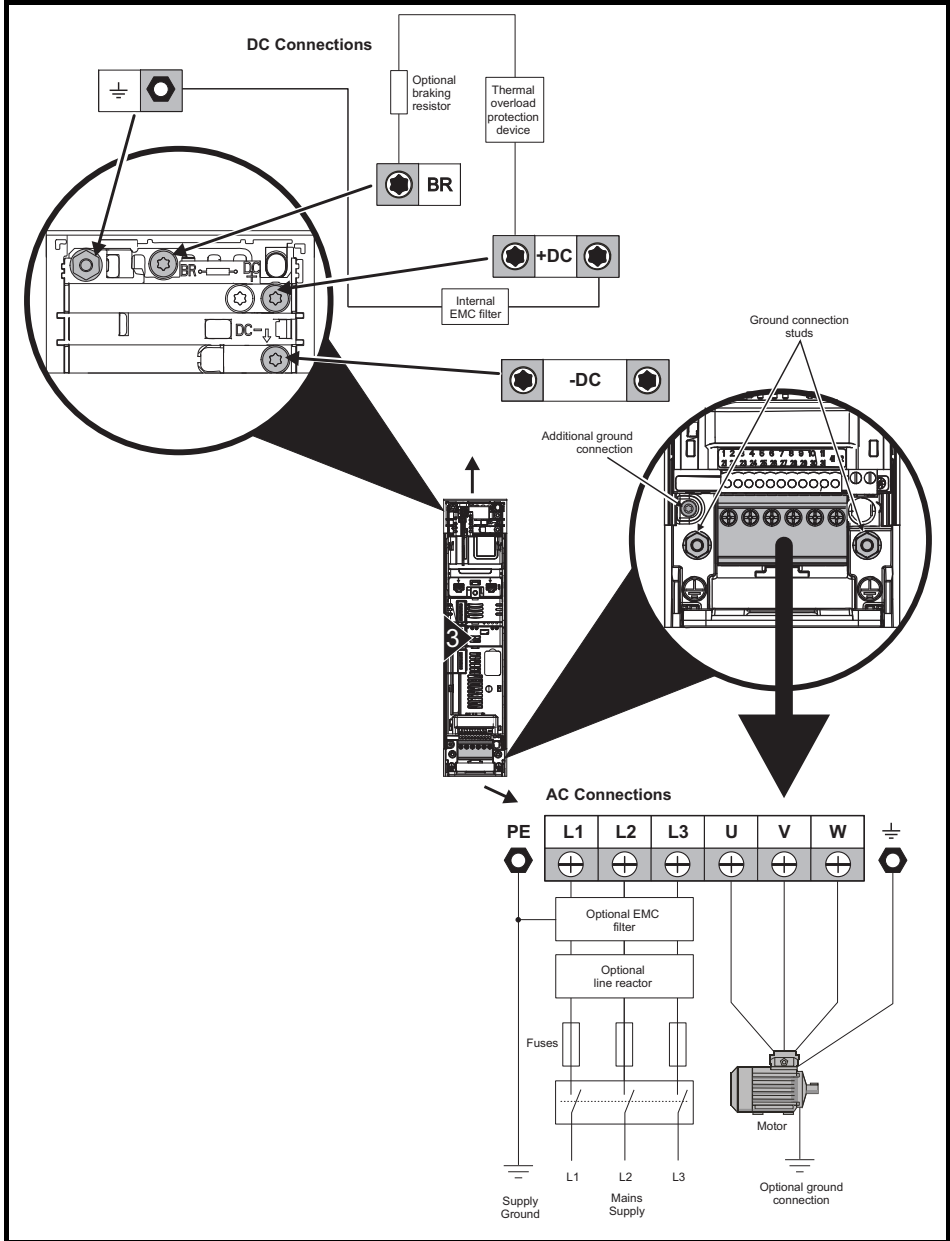
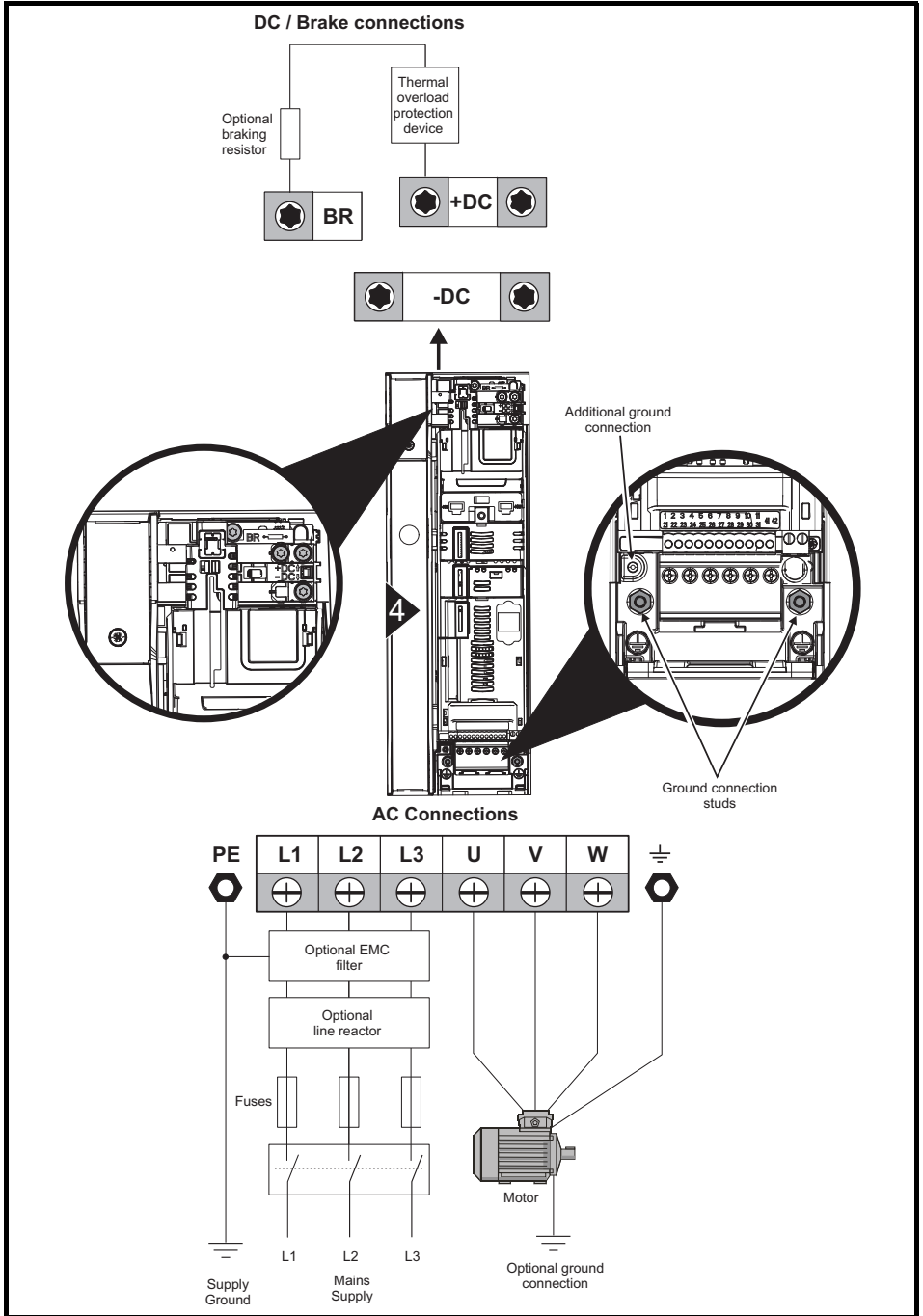

Figure 4-2 Size 4 power and ground connections



Safety information

Product information

Mechanical installation

Electrical installation

Getting started

Basic parameters

Running the motor

NV Media Card Operation

Further information

Figure 4-3 Size 5 power and ground connections

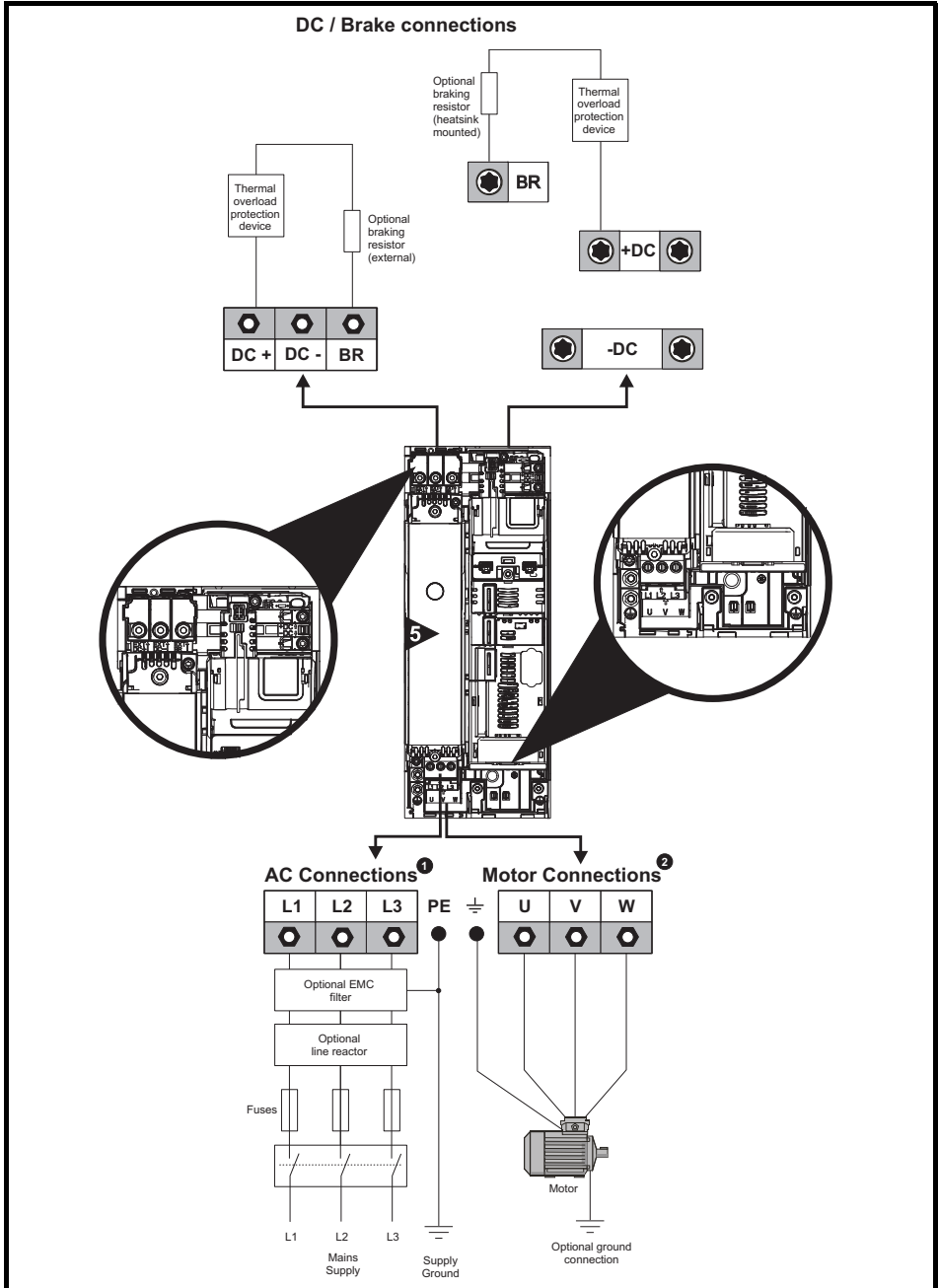

The upper terminal block (1) is used for AC supply connection.

The lower terminal block (2) is used for Motor connection.

Figure 4-4 Size 6 power and ground connections

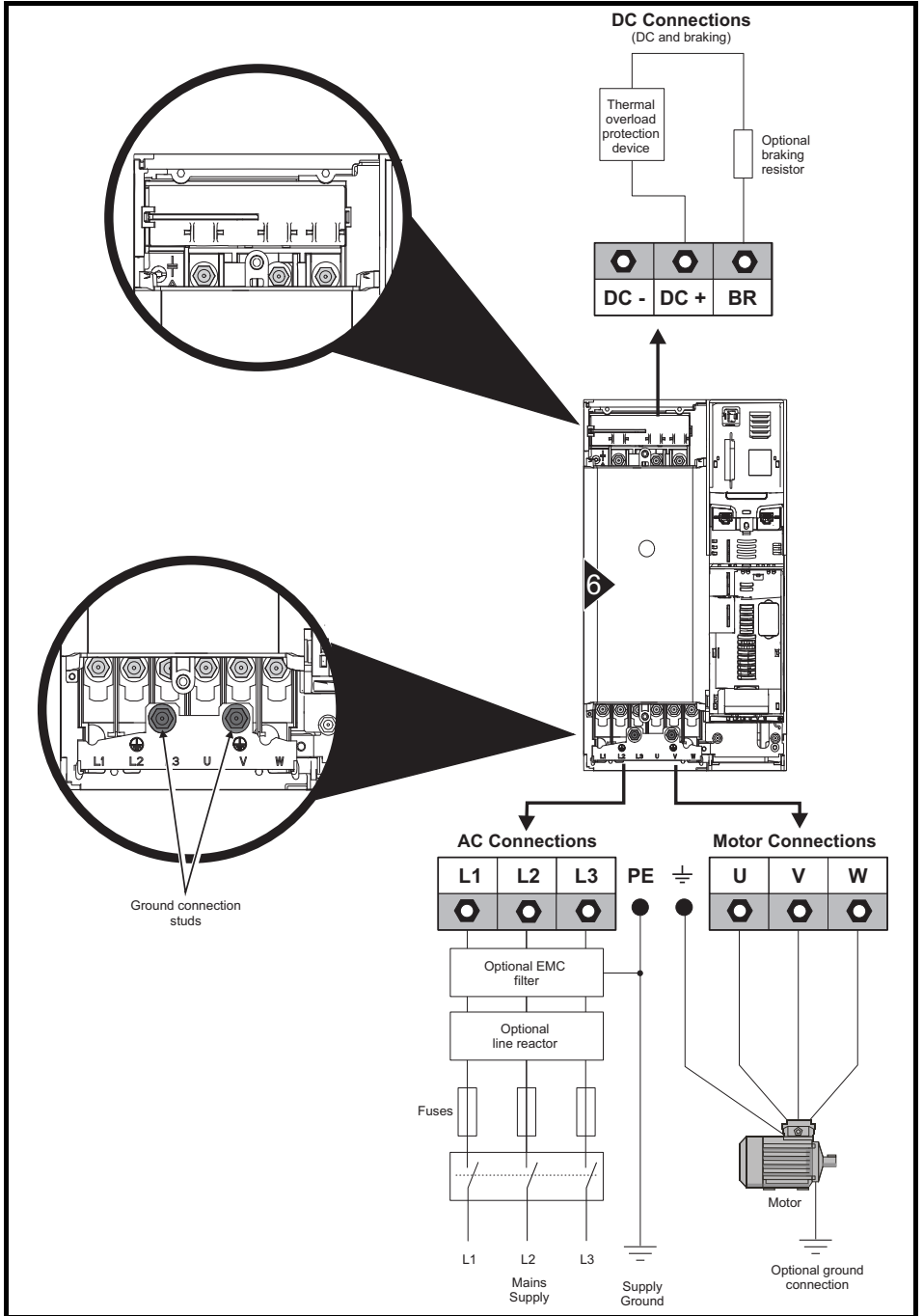

Figure 4-5 Size 7 and 8 power and ground connections (size 7 shown)

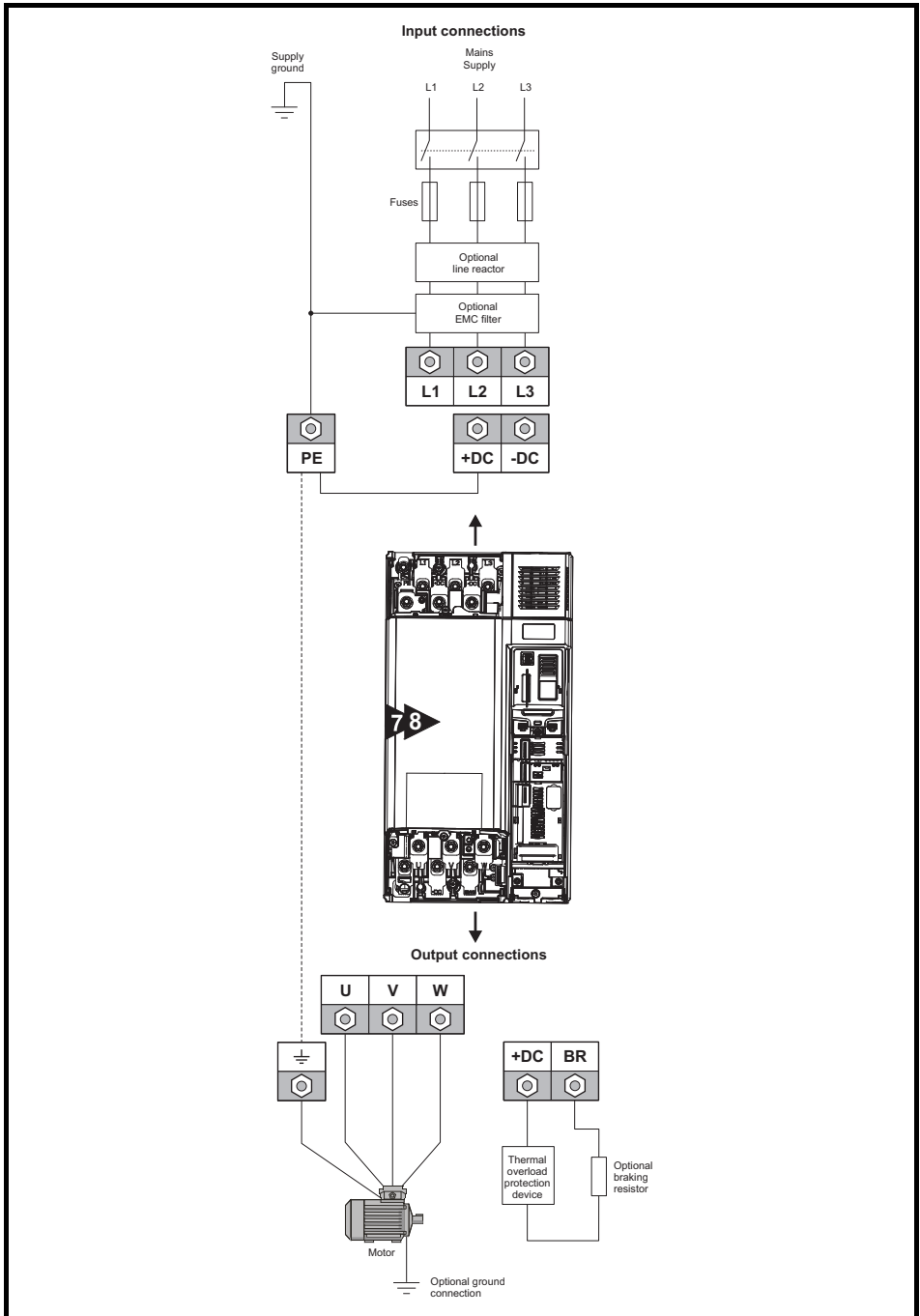
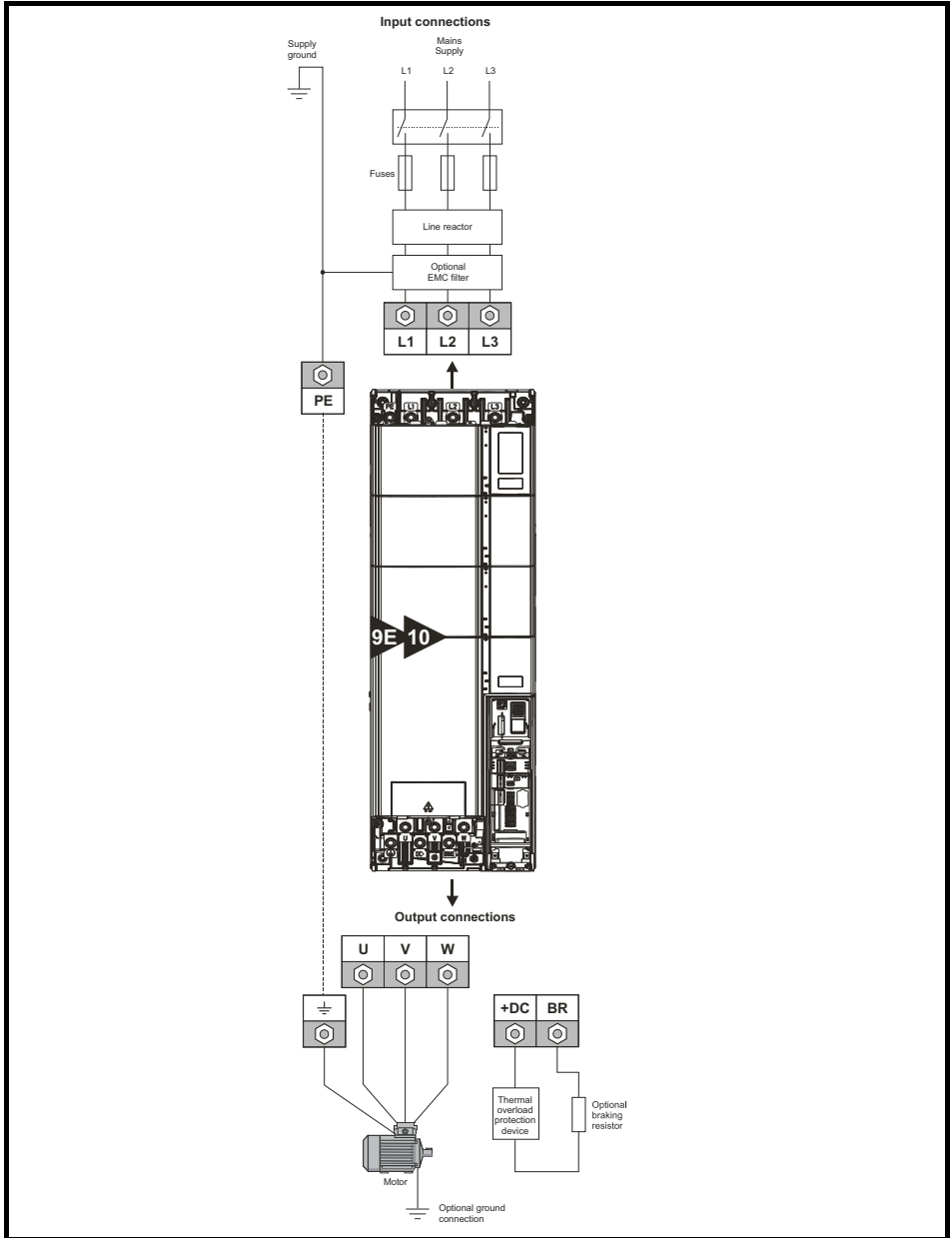

Figure 4-6 Size 9E and 10 power and ground connections



A separate line reactor (INLXXX) must be used for size 9E and 10. Failure to provide sufficient reactance could damage or reduce the service life of the drive. Refer to Table 2-8 *Size 9E and 10 model and line reactor part numbers* on page 12.

4.4 Ground connections



Electrochemical corrosion of grounding terminals

Ensure that grounding terminals are protected against corrosion i.e. as could be caused by condensation.

The drive must be connected to the system ground of the AC supply. The ground wiring must conform to local regulations and codes of practice.

NOTE

For further information on ground cable sizes, refer to Table 2-6 *Protective ground cable ratings* on page 11.

On size 3 and 4, the supply and motor ground connections are made using the M4 studs located either side of the drive near the plug-in power connectors. See Figure 4-1 and Figure 4-2 for details.

On size 5, the supply and motor ground connections are made using the M5 studs located near the plug-in power connector. Refer to Figure 4-3.

On size 6, the supply and motor ground connections are made using the M6 studs located above the supply and motor terminals. Refer to Figure 4-4.

On size 7, the supply and motor ground connections are made using the M8 studs located by the supply and motor connection terminals. Refer to Figure 4-5.

On size 8, the supply and motor ground connections are made using the M10 studs located by the supply and motor connection terminals. Refer to Figure 4-5.

On size 9E and 10, the supply and motor ground connections are made using the M10 studs located by the supply and motor connection terminals. Refer to Figure 4-6.



The ground loop impedance must conform to the requirements of local safety regulations.

The drive must be grounded by a connection capable of carrying the prospective fault current until the protective device (fuse, etc.) disconnects the AC supply.

The ground connections must be inspected and tested at appropriate intervals.

4.5 Braking resistor values

Table 4-1 Minimum resistance values and peak power rating for the braking resistor at 40 °C (104 °F)

Model	Minimum resistance * Ω	Instantaneous power rating kW	Continuous power rating kW	Model	Minimum resistance * Ω	Instantaneous power rating kW	Continuous power rating kW
200 V				575 V			
03200050	20	8.5	1.5	05500030	80	12.1	2.6
03200066			1.9	05500040			4.6
03200080			2.8	05500069			6.5
03200106			3.6	06500100	8.7		
04200137	18	9.4	4.6	06500150	13	74	12.3
04200185			6.3	06500190			16.3
05200250	16.5	10.3	8.6	06500230			19.9
06200330	8.6	19.7	12.6	06500290			24.2
06200440			16.4	06500350			31.7
07200610	6.1	27.8	20.5	07500440	8.5	113.1	39.5
07200750			24.4	07500550			47.1
07200830	4.5	37.6	32.5	08500630	5.5	174.8	58.6
08201160	2.2	76.9	41	08500860			78.1
08201320			47.8	09501040	97.7		
09201760			1.2	144.5	59.4	09501310	116.7
09202190	79.7	10501520			155.6		
10202830	1.3	130			98.6	10501900	155.6
10203000			116.7	690 V			
400 V				07600190	11.5	121.2	20.6
03400025	74	9.2	1.5	07600240			23.9
03400031			2.0	07600290			32.5
03400045			2.8	07600380			41.5
03400062			4.6	07600440			47.8
03400078	50	13.6	5.0	07600540			60.5
03400100			6.6	08600630	79.7		
04400150	34	19.9	9.0	08600860	5.5	253.5	95.2
04400172			12.6	09601040	4.2	331.9	116.3
05400270	31.5	21.5	16.2	09601310			139.1
05400300	18	37.5	19.6	10601500	4.2	331.9	166.7
06400350	17	39.8	21.6	10601780	3.3	422.4	193
06400420			25	* Resistor tolerance: ±10 %.			
06400470			32.7				
07400660	9.0	75.2	41.6				
07400770			50.6				
07401000			60.1				
08401340	4.8	140.9	81				
08401570			98.6				
09402000	2.4	282.9	118.6				
09402240			156.9				
10402700	2.6	260	198.2				
10403200			237.6				

Safety information
Product information
Mechanical installation
Electrical installation
Getting started
Basic parameters
Running the motor
NV Media Card Operation
Further information

4.6 Communications connections

The drive offers a 2 wire 485 serial interface. This enables the drive set-up, operation and monitoring to be carried out with a PC or controller if required. The drive provides two parallel RJ45 connectors allowing easy daisy chaining. The drive supports the Modbus RTU protocol. See Table 4-2 for the connection details.

Table 4-2 Serial communication port pin-outs

Pin	Function
1	120 Ω Termination resistor
2	RX TX
3	Isolated 0 V
4	+24 V (100 mA)
5	Isolated 0 V
6	TX enable
7	RX\ TX\
8	RX\ TX\ (if termination resistors are required, link to pin 1)
Shell	Isolated 0 V

4.7 Shield connections

The following guidelines should be followed to ensure suppression of radio-frequency emission and good noise immunity. It is particularly recommended that the guidelines for the encoder cable be followed closely in order to avoid disturbance to the encoder operation from electrical noise. Use the grounding bracket and grounding clamp supplied with the drive to terminate the shields at the drive.

Figure 4-7 Grounding of signal cable shields using the grounding bracket

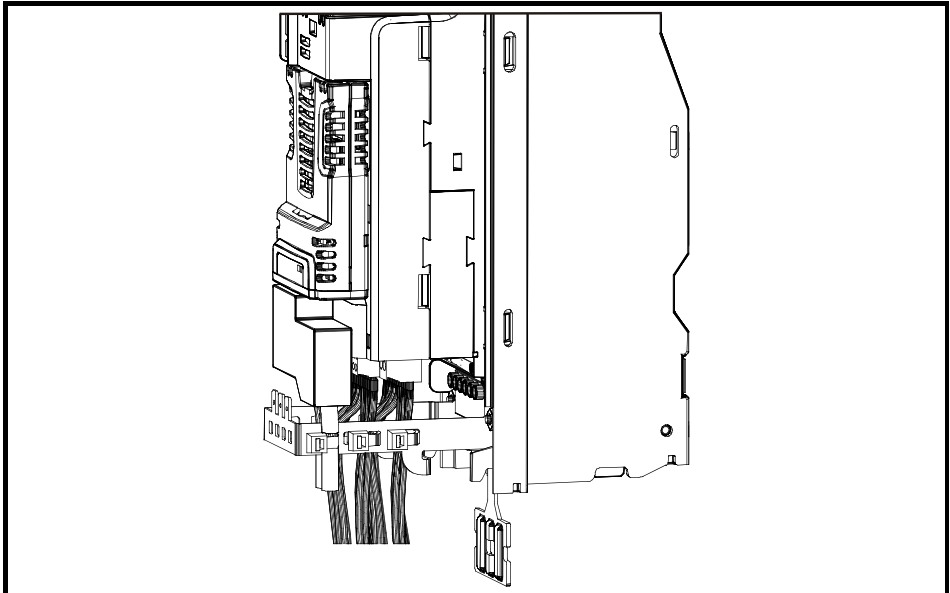

Motor cable: Use a motor cable with an overall shield. Connect the shield of the motor cable to the ground terminal of the motor frame using a link that is as short as possible and not exceeding 50 mm (2 in) long. A full 360 ° termination of the shield to the terminal housing of the motor is beneficial.

Encoder cable: For best shielding (when using an SI-Encoder option module), use cable with an overall shield and individual shields on twisted pairs, connect the cable as illustrated in Figure 4-8. Clamp the overall shield to grounded metallic surfaces at both the encoder and the drive.

Brake resistor cable: The optional braking resistor should also be wired with shielded cable. If unshielded wire is required refer to the *Drive User Guide* for guidance.

Control cables: If the control wiring is to leave the enclosure, it must be shielded and the shield(s) clamped to the drive using the grounding bracket. Remove the outer insulating cover of the cable to ensure the shield(s) make contact with the bracket, but keep the shield(s) intact until as close as possible to the terminals.

Figure 4-8 Feedback cable shield connections

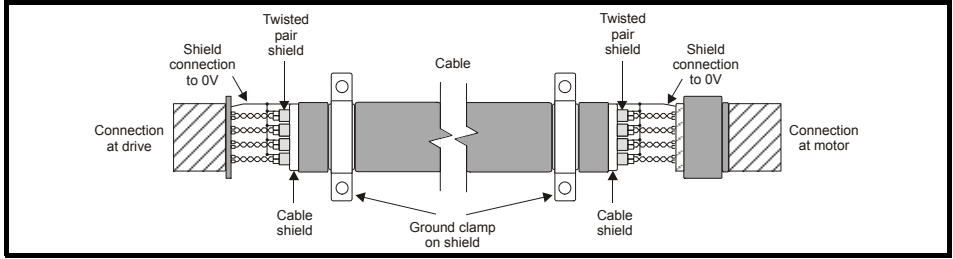

4.8 Control connections

For information on control connections, refer to the back cover of this guide.

5 Getting started

This chapter introduces the user interfaces, menu structure and security level of the drive.

5.1 Understanding the display

The keypad can only be mounted on the drive.

5.1.1 KI-Keypad

The KI-Keypad display consists of two rows of text. The upper row shows the drive status or the menu and parameter number currently being viewed. The lower row of the display line shows the parameter value or the specific trip type. The last two characters on the first row may display special indications. If more than one of these indications is active then the indications are prioritized as shown in Table 5-1.

When the drive is powered up the lower row will show the power up parameter defined by *Parameter Displayed At Power-up* (11.022).

Figure 5-1 KI-Keypad

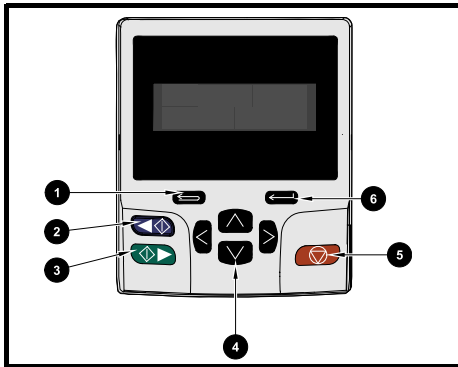

1. Escape button
2. Start reverse (Auxiliary button)
3. Start forward
4. Navigation keys (x4)
5. Stop / Reset (red) button
6. Enter button









NOTE The red stop  button is also used to reset the drive.

Table 5-1 Active action icon

Active action icon	Description	Row (1=top)	Priority in row
	Accessing non-volatile media card	1	1
	Alarm active	1	2
	Keypad real-time clock battery low	1	3
 or 	Drive security active and locked or unlocked	1	4
	Motor map 2 active	2	1
	User program running	3	1
	Keypad reference active	4	1

5.2 Keypad operation

5.2.1 Control buttons

The keypad consists of:

- Navigation Keys - Used to navigate the parameter structure and change parameter values.
- Enter / Mode button - Used to toggle between parameter edit and view mode.
- Escape / Exit button - Used to exit from parameter edit or view mode. In parameter edit mode, if parameter values are edited and the exit button pressed the parameter value will be restored to the value it had on entry to edit mode.
- Start forward button - Use to provide a 'Run' command if keypad mode is selected.
- Start reverse button - Used to control the drive if keypad mode is selected and the reverse button is activated.
- Stop / Reset button - Used to reset the drive. In keypad mode can be used for 'Stop'.

Figure 5-2 Display modes

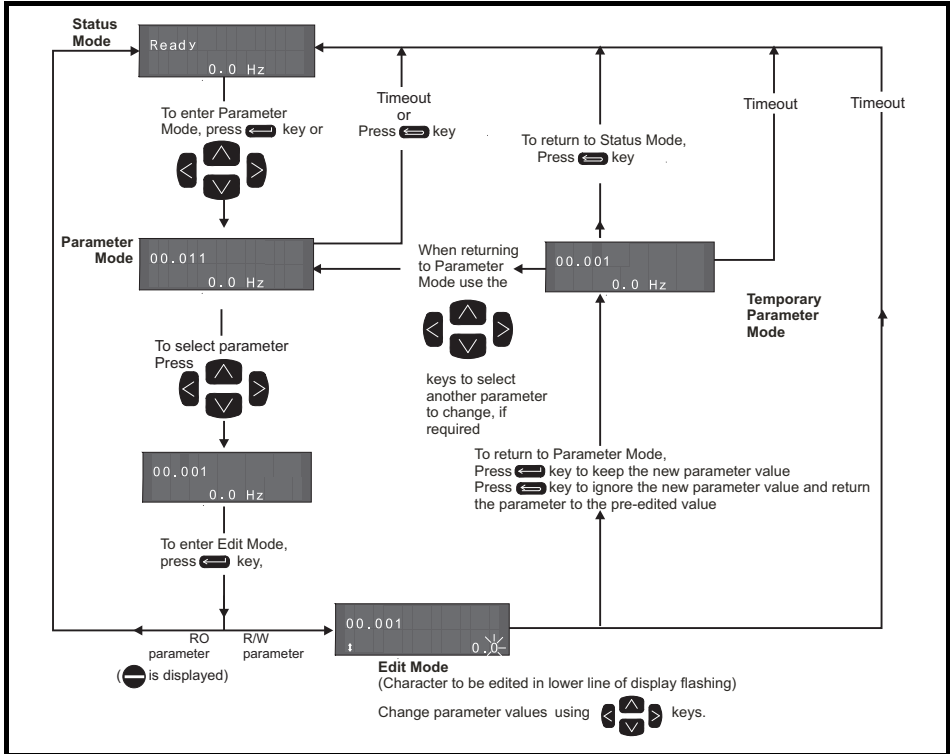

The navigation keys can only be used to move between menus if Pr **00.049** has been set to show 'All Menus'

Figure 5-3 Mode examples

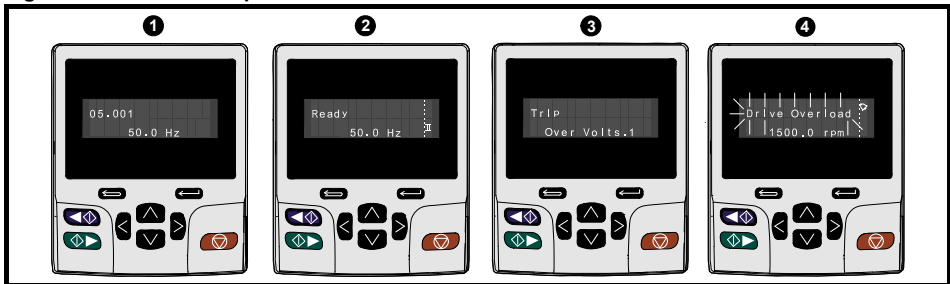

Do not change parameter values without careful consideration; incorrect values may cause damage or a safety hazard.

NOTE

When changing the values of parameters, make a note of the new values in case they need to be entered again.

NOTE

For new parameter-values to apply after the AC supply to the drive is interrupted, new values must be saved. Refer to section 5.7 *Saving parameters* on page 43.

5.3 Menu 0

Menu 0 is used to bring together various commonly used parameters for basic easy set up of the drive. Appropriate parameters are copied from the advanced menus into menu 0 and thus exist in both locations. For further information, refer to Chapter 6 *Basic parameters (Menu 0)* on page 45.

5.4 Menu structure

The drive parameter structure consists of menus and parameters. The drive initially powers up so that only Menu 0 can be viewed. The up and down arrow buttons are used to navigate between parameters and once Pr **00.049** has been set to 'All Menus' the left and right buttons are used to navigate between menus. For further information, refer to section 5.11 *Parameter access level and security* on page 44.

Figure 5-4 Menu structure

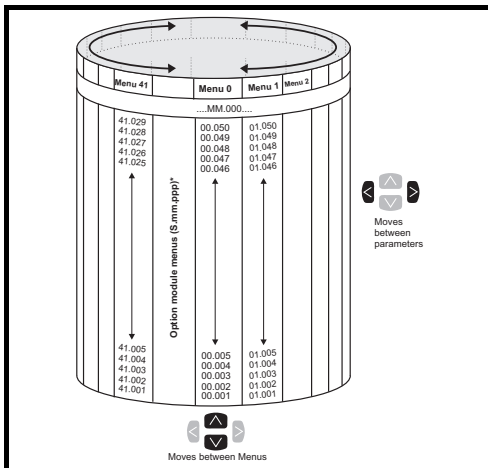

The menus and parameters roll over in both directions. i.e. if the last parameter is displayed, a further press will cause the display to rollover and show the first parameter.

When changing between menus the drive remembers which parameter was last viewed in a particular menu and thus displays that parameter.

* The option module menus (S.mm.ppp) are only displayed if option modules are installed. Where S signifies the option module slot number and the mm.ppp signifies the menu and the parameter number of the option module's internal menus and parameter.

5.5 Advanced menus

The advanced menus consist of groups or parameters appropriate to a specific function or feature of the drive. Menus 0 to 41 can be viewed on the KI-Keypad.

Table 5-2 Advanced menu descriptions

Menu	Description
0	Commonly used basic set-up parameters for quick / easy programming
1	Frequency / speed reference
2	Ramps
3	Frequency slaving, speed feedback and speed control
4	Torque and current control
5	Motor control
6	Sequencer and clock
7	Analog I/O, Temperature monitoring
8	Digital I/O
9	Programmable logic, motorized pot, binary sum, timers and scope
10	Status and trips
11	Drive set-up and identification, serial communications
12	Threshold detectors and variable selectors
13	Standard motion control
14	User PID controller
15	Option module slot 1 set-up menu
16	Option module slot 2 set-up menu
17	Option module slot 3 set-up menu
18	General option module application menu 1
19	General option module application menu 2
20	General option module application menu 3
21	Second motor parameters
22	Menu 0 set-up
23	Not allocated
28	Not allocated
29	Reserved menu
30	Onboard user programming application menu
Slot 1	Slot 1 option menus*
Slot 2	Slot 2 option menus*
Slot 3	Slot 3 option menus*

* Only displayed when the option modules are installed.

5.6 Changing the operating mode

Changing the operating mode returns all parameters to their default value, including the motor parameters. *User security status* (00.049) and *User security code* (00.034) are not affected by this procedure).

Procedure

Use the following procedure only if a different operating mode is required:

1. Ensure the drive is not enabled, i.e. terminal 31 is open or Pr **06.015** is OFF (0)
2. Enter either of the following values in Pr **mm.000**, as appropriate:
 - 1253 (50Hz AC supply frequency)
 - 1254 (60Hz AC supply frequency)
3. Change the setting of Pr **00.048** as follows:

Pr 00.048 setting		Operating mode
	1	Open-loop (Induction motor)
	2	RFC-A (Induction motor with or without position feedback)
	3	RFC-S (Permanent magnet motor without position feedback)

The figures in the second column apply when serial communications are used.

4. Either:
 - Press the red reset button
 - Toggle the reset digital input
 - Carry out a drive reset through serial communications by setting Pr **10.038** to 100.

NOTE Entering 1253 or 1254 in Pr **mm.000** will only load defaults if the setting of Pr **00.048** has been changed.

5.7 Saving parameters

When changing a parameter in Menu 0, the new value is saved when pressing the Enter button to return to parameter view mode from parameter edit mode.

If parameters have been changed in the advanced menus, then the change will not be saved automatically. A save function must be carried out.

Procedure

1. Select 'Save Parameters'* in Pr **mm.000** (alternatively enter a value of 1000* in Pr **mm.000**)
2. Either:
 - Press the red reset button
 - Toggle the reset digital input, or
 - Carry out a drive reset through serial communications by setting Pr **10.038** to 100

* If the drive is in the under voltage state (i.e. when the control terminal 1 & 2 are being supplied from a low voltage DC supply) a value of 1001 must be entered into Pr **mm.000** to perform a save function.

5.8 Restoring parameter defaults

Restoring parameter defaults by this method saves the default values in the drives memory. *User security status* (00.049) and *User security code* (00.034) are not affected by this procedure).

Procedure

1. Ensure the drive is not enabled, i.e. terminal 31 is open or Pr **06.015** is OFF (0)
2. Select 'Reset 50 Hz Defs' or 'Reset 60 Hz Defs' in Pr **mm.000**. (alternatively, enter 1233 (50 Hz settings) or 1244 (60 Hz settings) in Pr **mm.000**).
3. Either:
 - Press the red  reset button
 - Toggle the reset digital input
 - Carry out a drive reset through serial communications by setting Pr **10.038** to 100

5.9 Displaying parameters with non-default values only

By selecting 'Show non-default' in Pr **mm.000** (Alternatively, enter 12000 in Pr **mm.000**), the only parameters that will be visible to the user will be those containing a non-default value. This function does not require a drive reset to become active. In order to deactivate this function, return to Pr **mm.000** and select 'No action' (alternatively enter a value of 0). Please note that this function can be affected by the access level enabled, refer to section 5.11 *Parameter access level and security* on page 44 for further information regarding access level.

5.10 Displaying destination parameters only

By selecting 'Destinations' in Pr **mm.000** (Alternatively enter 12001 in Pr **mm.000**), the only parameters that will be visible to the user will be destination parameters. This function does not require a drive reset to become active. In order to deactivate this function, return to Pr **mm.000** and select 'No action' (alternatively enter a value of 0).

Please note that this function can be affected by the access level enabled, refer to section 5.11 *Parameter access level and security* for further information regarding access level.

5.11 Parameter access level and security

The parameter access level determines whether the user has access to Menu 0 only or to all the advanced menus (Menus 1 to 41) in addition to Menu 0. The User Security determines whether the access to the user is read only or read write. Both the User Security and Parameter Access Level can operate independently of each other as shown in Table 5-3.

Table 5-3 Parameter access level and security

User security status (11.044)	Access level	User security	Menu 0 status	Advanced menu status
0	Menu 0	Open	RW	Not visible
		Closed	RO	Not visible
1	All Menus	Open	RW	RW
		Closed	RO	RO
2	Read-only Menu 0	Open	RO	Not visible
		Closed	RO	Not visible
3	Read-only	Open	RO	RO
		Closed	RO	RO
4	Status only	Open	Not visible	Not visible
		Closed	Not visible	Not visible
5	No access	Open	Not visible	Not visible
		Closed	Not visible	Not visible

The default settings of the drive are Parameter Access Level Menu 0 and User Security Open i.e. read / write access to Menu 0 with the advanced menus not visible.

6 Basic parameters (Menu 0)

Parameter			Range			Default			Type						
			OL	RFC-A	RFC-S	OL	RFC-A	RFC-S							
00.001	Minimum Reference Clamp	{01.007}	±VM_NEGATIVE_REF_CLAMP1 Hz / rpm			0 Hz / rpm			RW	Num					US
00.002	Maximum Reference Clamp1	{01.006}	±VM_POSITIVE_REF_CLAMP1 Hz / rpm			50 Hz: 50.0 Hz 60 Hz: 60.0 Hz	50 Hz: 1500.0 rpm 60 Hz: 1800.0 rpm		RW	Num					US
00.003	Acceleration Rate 1	{02.011}	±VM_ACCEL_RATE s/100 Hz	±VM_ACCEL_RATE s/1000 rpm		5.0 s/ 100 Hz	2.000 s/1000 rpm		RW	Num					US
00.004	Deceleration Rate 1	{02.021}	±VM_ACCEL_RATE s/100 Hz	±VM_ACCEL_RATE s/1000 rpm		10.0 s/ 100 Hz	2.000 s/1000 rpm		RW	Num					US
00.005	Reference Selector	{01.014}	A1 A2 (0), A1 Preset (1), A2 Preset (2) Preset (3), Keypad (4), Precision (5) Keypad Ref (6)			A1 A2 (0)			RW	Txt					US
00.006	Symmetrical Current Limit	{04.007}	±VM_MOTOR1_CURRENT_LIMIT %			165.0 %	175.0 %		RW	Num		RA			US
00.007	Open-loop Control Mode / Action On Enable	{05.014}	Ur S (0), Ur (1), Fixed (2), Ur Auto (3), Ur I (4), Square (5), Current 1P (6)			Ur I (4)			RW	Txt					US
	Speed Controller Proportional Gain Kp1	{03.010}				0.0000 to 200.000 s/rad		0.0300 s/rad	RW	Num					US
00.008	Low Frequency Voltage Boost	{05.015}	0.0 to 25.0 %			3.0 %			RW	Num					US
	Speed Controller Integral Gain Ki1	{03.011}				0.00 to 655.35 s ² /rad		0.10 s ² /rad	RW	Num					US
00.009	Dynamic V to F Select	{05.013}	Off (0) or On (1)			Off (0)			RW	Bit					US
	Speed Controller Differential Feedback Gain Kd 1	{03.012}				0.00000 to 0.65535 1/rad		0.00000 1/rad	RW	Num					US
00.010	Motor Rpm	{05.004}	±180000 rpm						RO	Num	ND	NC	PT	FI	
	Speed Feedback	{03.002}				±VM_SPEED rpm			RO	Num	ND	NC	PT	FI	
00.011	Output Frequency	{05.001}	±VM_SPEED_FREQ_REF Hz						RO	Num	ND	NC	PT	FI	
	P1 Position	{03.029}				0 to 65535			RO	Num	ND	NC	PT	FI	
00.012	Current Magnitude	{04.001}	±VM_DRIVE_CURRENT_UNIPOLAR A						RO	Bit	ND	NC	PT	FI	
00.013	Torque Producing Current	{04.002}	±VM_DRIVE_CURRENT A						RO	Bit	ND	NC	PT	FI	
00.014	Torque Mode Selector	{04.011}	0 or 1	0 to 5		0			RW	Num					US
00.015	Ramp Mode Select	{02.004}	Fast (0), Standard (1), Std boost (2)	Fast (0), Standard (1)		Standard (1)			RW	Txt					US

Safety information

Product information

Mechanical installation

Electrical installation

Getting started

Basic parameters

Running the motor

NV Media Card Operation

Further information

Parameter			Range			Default			Type					
			OL	RFC-A	RFC-S	OL	RFC-A	RFC-S						
00.016	Ramp Enable	{02.002}		Off (0) or On (1)			On (1)		RW	Bit				US
00.017	Digital Input 6 Destination	{08.026}	0.000 to 59.999			06.031			RW	Num	DE		PT	US
	Current Reference Filter 1 Time Constant	{04.012}		0.0 to 25.0 ms			1.0 ms		RW	Num				US
00.019	Analog Input 2 Mode	{07.011}	4-20 mA Low (-4), 20-4 mA Low (-3), 4-20 mA Hold (-2), 20-4 mA Hold (-1), 0-20 mA (0), 20-0 mA (1), 4-20 mA Trip (2), 20-4 mA Trip (3), 4-20 mA (4), 20-4 mA (5), Volt (6)				Volt (6)		RW	Txt				US
00.020	Analog Input 2 Destination	{07.014}	00.000 to 59.999				01.037		RW	Num	DE		PT	US
00.021	Analog Input 3 Mode	{07.015}	Volt (6), Therm Short Cct (7), Thermistor (8), Therm No Trip (9)				Volt (6)		RW	Txt				US
00.022	Bipolar Reference Enable	{01.010}	Off (0) or On (1)				Off (0)		RW	Bit				US
00.023	Jog Reference	{01.005}	0.0 to 400.0 Hz	0.0 to 4000.0 rpm			0.0 Hz / rpm		RW	Num				US
00.024	Preset Reference 1	{01.021}	±VM_SPEED_FREQ_REF Hz / rpm				0.0 Hz / rpm		RW	Num				US
00.025	Preset Reference 2	{01.022}	±VM_SPEED_FREQ_REF Hz / rpm				0.0 Hz / rpm		RW	Num				US
00.026	Preset Reference 3	{01.023}	±VM_SPEED_FREQ_REF Hz			0.0 Hz			RW	Num				US
	Overspeed Threshold	{03.008}		0 to 40000 rpm			0 rpm		RW	Num				US
00.027	Preset Reference 4	{01.024}	±VM_SPEED_FREQ_REF Hz			0.0 Hz			RW	Num				US
00.028	Enable Auxiliary Key	{06.013}	Disabled (0), Forward / Reverse (1), Reverse (2)				Disabled (0)		RW	Num				US
00.029	NV Media Card Data Previously Loaded	{11.036}	0 to 999				0		RO	Num		NC	PT	
00.030	Parameter Cloning	{11.042}	None (0), Read (1), Program (2), Auto (3), Boot (4)				None (0)		RW	Txt		NC		US
00.031	Rated Voltage	{11.033}	200 V (0), 400 V (1), 575 V (2), 690 V (3)						RO	Txt	ND	NC	PT	
00.032	Maximum Heavy Duty Rating	{11.032}	0.000 to 99999.999 A						RO	Num	ND	NC	PT	
00.033	Catch A Spinning Motor	{06.009}	Disable (0), Enable (1), Fwd Only (2), Rev Only (3)				Disable (0)		RW	Txt				US
	Motor Parameter Adaptive Control	{05.016}		0 to 2			0		RW	Num				US
00.034	User Security Code	{11.030}	0 to 2147483647				0		RW	Num	ND	NC	PT	US
00.035	Serial Mode	{11.024}	8 2 NP (0), 8 1 NP (1), 8 1 EP (2), 8 1 OP (3), 8 2 NP M (4), 8 1 NP M (5), 8 1 EP M (6), 8 1 OP M (7), 7 2 NP (8), 7 1 NP (9), 7 1 EP (10), 7 1 OP (11), 7 2 NP M (12), 7 1 NP M (13), 7 1 EP M (14), 7 1 OP M (15)				8 2 NP (0)		RW	Txt				US
00.036	Serial Baud Rate	{11.025}	300 (0), 600 (1), 1200 (2), 2400 (3), 4800 (4), 9600 (5), 19200 (6), 38400 (7), 57600 (8), 76800 (9), 15200 (10)				19200 (6)		RW	Txt				US

Parameter			Range			Default			Type					
			OL	RFC-A	RFC-S	OL	RFC-A	RFC-S						
00.037	Serial Address	{11.023}	1 to 247			1			RW	Num				US
00.038	Current Controller Kp Gain	{04.013}	0 to 30000			20	150		RW	Num				US
00.039	Current Controller Ki Gain	{04.014}	0 to 30000			40	2000		RW	Num				US
00.040	Auto-tune	{05.012}	0 to 2	0 to 5	0 to 6	0			RW	Num		NC		
00.041	Maximum Switching Frequency	{05.018}	2 kHz (0), 3 kHz (1), 4 kHz (2), 6 kHz (3), 8 kHz (4), 12 kHz (5), 16 kHz (6)			3 kHz (1)			RW	Txt		RA		US
00.042	Number Of Motor Poles	{05.011}	Automatic (0) to 480 Poles (240)			Automatic (0)		6 Poles (3)	RW	Num				US
00.043	Rated Power Factor	{05.010}	0.000 to 1.000			0.850			RW	Num		RA		US
00.044	Rated Voltage	{05.009}	±VM_AC_VOLTAGE_SET V			200V drive: 230V 50Hz default 400V drive: 400V 60Hz default 400V drive: 460V 575V drive: 575V			RW	Num		RA		US
00.045	Rated Speed	{05.008}	0 to 33000 rpm	0.00 to 33000.00 rpm		Eur - 1500 rpm USA - 1800 rpm	Eur - 1450.0 rpm USA - 1750.0 rpm	3000.00 rpm	RW	Num				US
00.046	Rated Current	{05.007}	±VM_RATED_CURRENT A			Maximum Heavy Duty Rating (11.032) A			RW	Num		RA		US
00.047	Rated Frequency	{05.006}	0.0 to 550.0 Hz			50Hz: 50.0 60Hz: 60.0			RW	Num				US
	Volts per 1000 rpm	{05.033}			0 to 10000 V / 1000 rpm			98 V / 1000 rpm	RW	Num				US
00.048	User Drive Mode	{11.031}	Open-loop (1), RFC-A (2), RFC-S (3), Regen (4)			Open-loop (1)	RFC-A (2)	RFC-S (3)	RW	Txt	ND	NC	PT	
00.049	User Security Status	{11.044}	Menu 0 (0), All Menus (1), Read-only Menu 0 (2), Read-only (3), Status Only (4), No Access (5)			Menu 0 (0)			RW	Txt	ND		PT	
00.050	Software Version	{11.029}	0 to 99999999						RO	Num	ND	NC	PT	
00.051	Action On Trip Detection	{10.037}	00000 to 11111			00000			RW	Bin				US
00.052	Reset Serial Communications	{11.020}	Off (0) or On (1)			Off (0)			RW	Bit	ND	NC		
00.053	Motor Thermal Time Constant 1	{04.015}	1.0 to 3000.0 s			89.0 s			RW	Num				US
00.054	RFC Low Speed Mode	{05.064}			Injection (0), Non-salient (1)			Non-salient (1)	RW	Txt				US
00.055	Low Speed Sensorless Mode Current	{05.071}			0.0 to 1000.0 %			20.0 %	RW	Num		RA		US
00.056	No-load Lq	{05.072}			0.000 to 500.000 mH			0.000 mH	RW	Num		RA		US

Safety Information
Product Information
Mechanical Installation
Electrical Installation
Getting started
Basic parameters
Running the motor
NV Media Card Operation
Further information

Parameter			Range			Default			Type					
			OL	RFC-A	RFC-S	OL	RFC-A	RFC-S						
00.057	Iq Test Current or Inductance Measurement	{05.075}			0 to 200 %			100 %	RW	Num				US
00.058	Phase Offset At Iq Test Current	{05.077}			±90.0 °			0.0 °	RW	Num		RA		US
00.059	Lq At The Defined Iq Test Current	{05.078}			0.000 to 500.000 mH			0.000 mH	RW	Num		RA		US
00.060	Id Test Current for Inductance Measurement	{05.082}			-100 to 0 %			-50 %	RW	Num				US
00.061	Lq At The Defined Id Test Current	{05.084}			0.000 to 500.000 mH			0.000 mH	RW	Num		RA		US

¹ RW = Read Write, RO = Read Only.

6.1 Parameter descriptions

6.1.1 Pr mm.000

Pr **mm.000** is available in all menus, commonly used functions are provided as text strings in Pr **mm.000** shown in Table 6-1. The functions in Table 6-1 can also be selected by entering the appropriate numeric values (as shown in Table 6-2) in Pr **mm.000**. For example, enter 4001 in Pr **mm.000** to erase the file in NV media card location 001.

Table 6-1 Commonly used functions in Pr mm.000

String	Action
Save parameters	Save parameters when under voltage is not active and low voltage threshold is not active
Load file 1	Load the drive parameters or user program file from NV media card file 001
Save to file 1	Transfer the drive parameters to parameter file 001
Load file 2	Load the drive parameters or user program file from NV media card file 002
Save to file 2	Transfer the drive parameters to parameter file 002
Load file 3	Load the drive parameters or user program file from NV media card file 003
Save to file 3	Transfer the drive parameters to parameter file 003
Show non-default	Displays parameters that are different from defaults
Destinations	Displays parameters that are set
Reset 50Hz Defs	Load parameters with standard (50 Hz) defaults
Reset 60Hz Defs	Load parameters with US (60 Hz) defaults
Reset modules	Reset all option modules
Read Enc.NP P1	No function
Read Enc.NP P2	No function

Table 6-2 Functions in Pr mm.000

Value	Action
1000	Save parameters when <i>Under Voltage Active</i> (Pr 10.016) is not active and <i>Low Under Voltage Threshold Select</i> mode (Pr 06.067 = Off) is not active.
1001	Save parameter under all conditions
1070	Reset all option modules
1233	Load standard (50 Hz) defaults
1234	Load standard (50 Hz) defaults to all menus except option module menus (i.e 15 to 20 and 24 to 28)
1244	Load US (60 Hz) defaults
1245	Load US (60 Hz) defaults to all menus except option module menus (i.e 15 to 20 and 24 to 28)
1253	Change drive mode and load standard (50 Hz) defaults
1254	Change drive mode and load US (60 Hz) defaults
1255	Change drive mode and load standard (50 Hz) defaults except for menus 15 to 20 and 24 to 28
1256	Change drive mode and load US (60 Hz) defaults except for menus 15 to 20 and 24 to 28
1299	Reset {Stored HF} trip.
2001*	Create a boot file on a non-volatile media card based on the present drive parameters including all Menu 20 parameters
4yyy*	NV media card: Transfer the drive parameters to parameter file xxx
5yyy*	NV media card: Transfer the onboard user program to onboard user program file xxx
6yyy*	NV media card: Load the drive parameters from parameter file xxx or the onboard user program from onboard user program file xxx
7yyy*	NV media card: Erase file xxx
8yyy*	NV Media card: Compare the data in the drive with file xxx
9555*	NV media card: Clear the warning suppression flag
9666*	NV media card: Set the warning suppression flag
9777*	NV media card: Clear the read-only flag
9888*	NV media card: Set the read-only flag
9999*	NV media card: Erase and format the NV media card
12000**	Only display parameters that are different from their default value. This action does not require a drive reset.
12001**	Only display parameters that are used to set-up destinations (i.e. DE format bit is 1). This action does not require a drive reset.

* See section 8 *NV Media Card Operation* on page 66 for more information on these functions.

** These functions do not require a drive reset to become active. All other functions require a drive reset to initiate the function.

Safety information	Product information	Mechanical installation	Electrical installation	Getting started	Basic parameters	Running the motor	NV Media Card Operation	Further information
--------------------	---------------------	-------------------------	-------------------------	-----------------	-------------------------	-------------------	-------------------------	---------------------

Figure 6-1 Menu 0 logic diagram

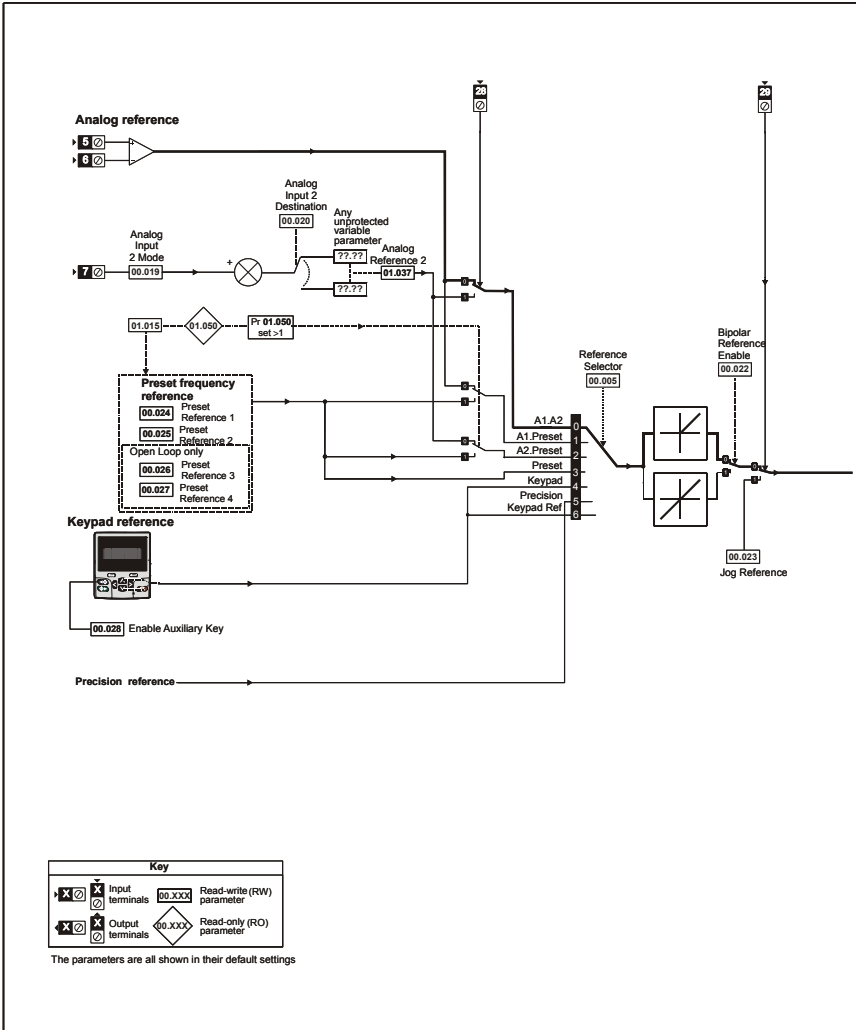

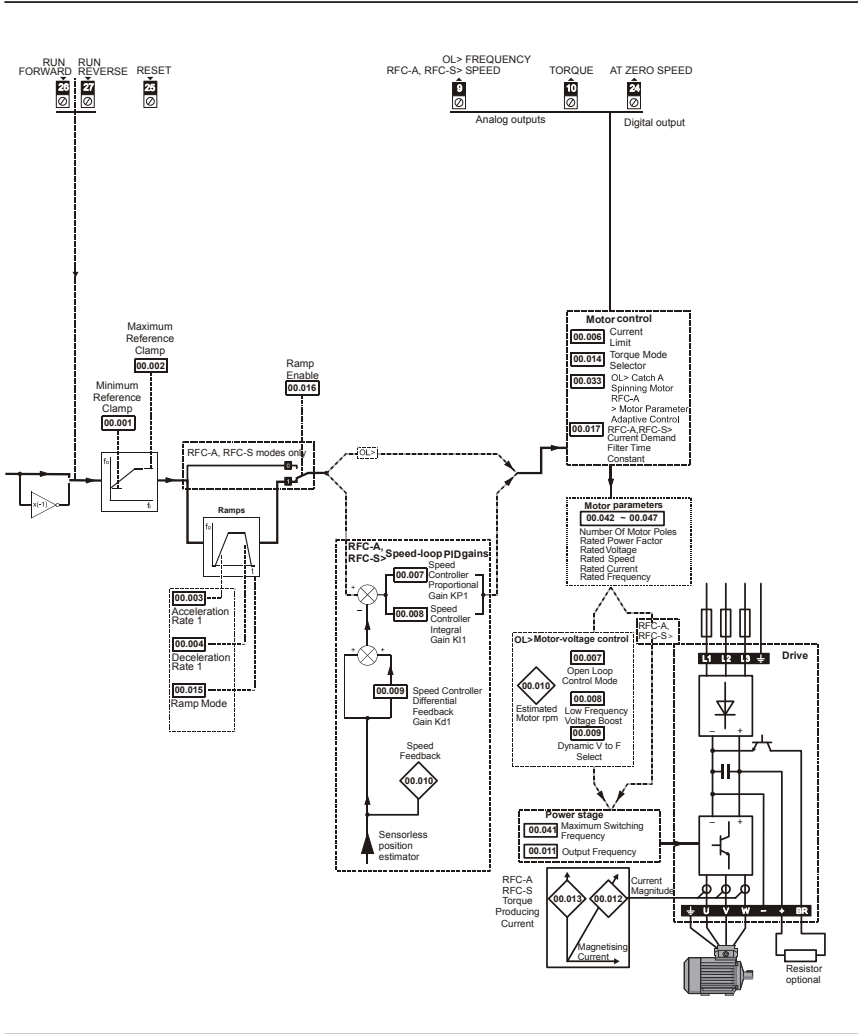

Safety information
Product information
Mechanical installation
Electrical installation
Getting started
Basic parameters
Running the motor
NV Media Card Operation
Further information

7 Running the motor

This chapter takes the new user through all the essential steps to running a motor for the first time, in each of the possible operating modes.



Ensure that no damage or safety hazard could arise from the motor starting unexpectedly.



The values of the motor parameters affect the protection of the motor.

The default values in the drive should not be relied upon.

It is essential that the correct value is entered in Pr **00.046 Rated Current**. This affects the thermal protection of the motor.



If the drive is started using the keypad it will run to the speed defined by the keypad

reference (Pr **02.017**). This may not be acceptable depending on the application. The user must check in Pr **01.017** and ensure that the keypad reference has been set to 0.



If the intended maximum speed affects the safety of the machinery, additional independent over-speed protection must be used.

7.1 Quick start connections

7.1.1 Basic requirements

This section shows the basic connections which must be made for the drive to run in the required mode. For minimal parameter settings to run in each mode please see the relevant part of section 7.2 *Quick Start / start-up* on page 59.

Table 7-1 Minimum control connection requirements for each control mode

Drive control method	Requirements
Terminal mode	Drive enable Speed / Torque reference Run forward / Run reverse
Keypad mode	Drive enable
Communications	Drive enable Communications link

Table 7-2 Minimum control connection requirements for each mode of operation

Operating mode	Requirements
Open loop mode	Induction motor
RFC - A sensorless (without feedback position)	Induction motor with speed feedback
RFC - S sensorless (without position feedback)	Permanent magnet motor with speed and position feedback

Figure 7-1 Minimum connections to get the motor running in any operating mode (size 3 and 4)

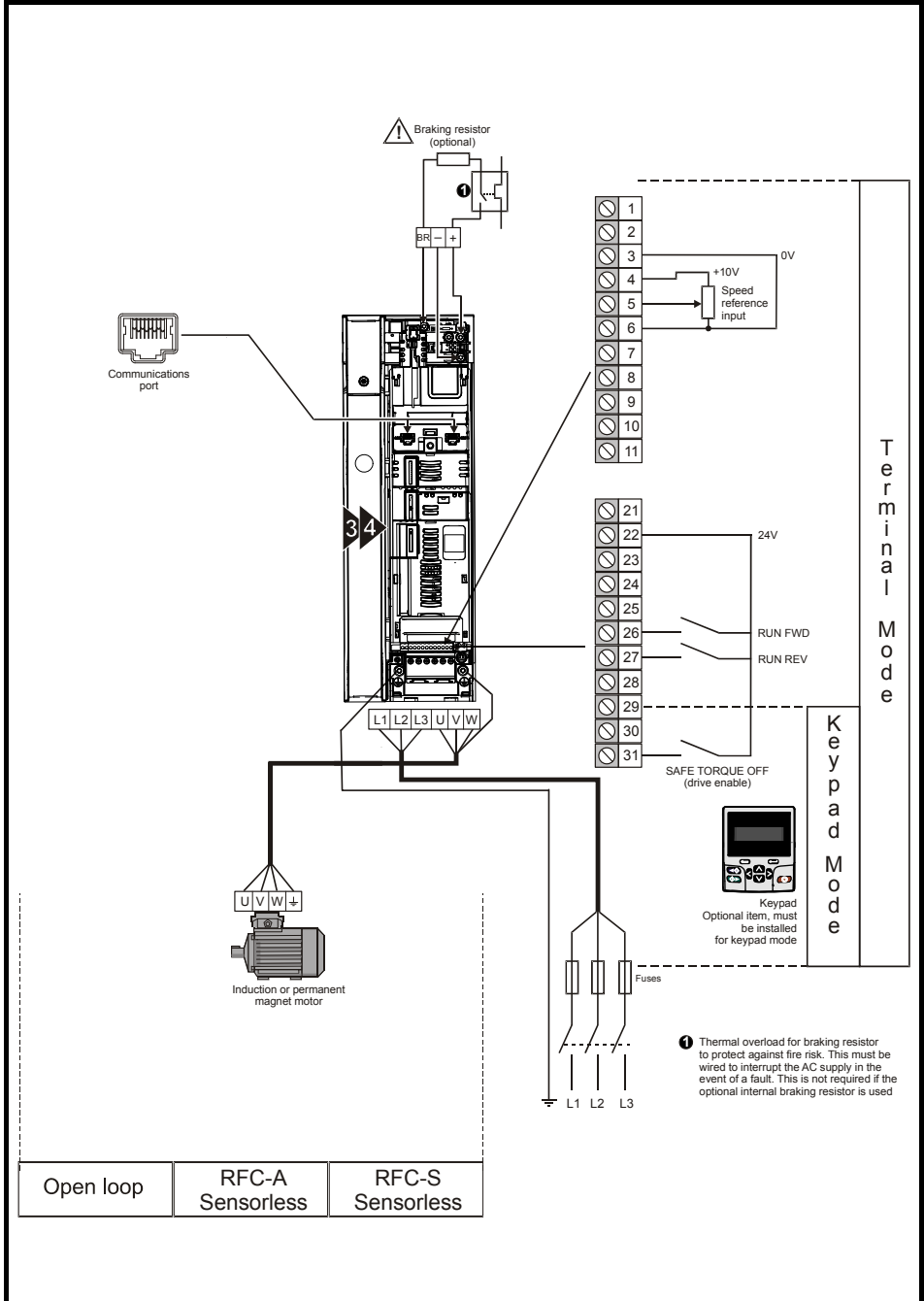

Safety information
Product information
Mechanical installation
Electrical installation
Getting started
Basic parameters
Running the motor
NV Media Card Operation
Further information

Figure 7-2 Minimum connections to get the motor running in any operating mode (size 5)

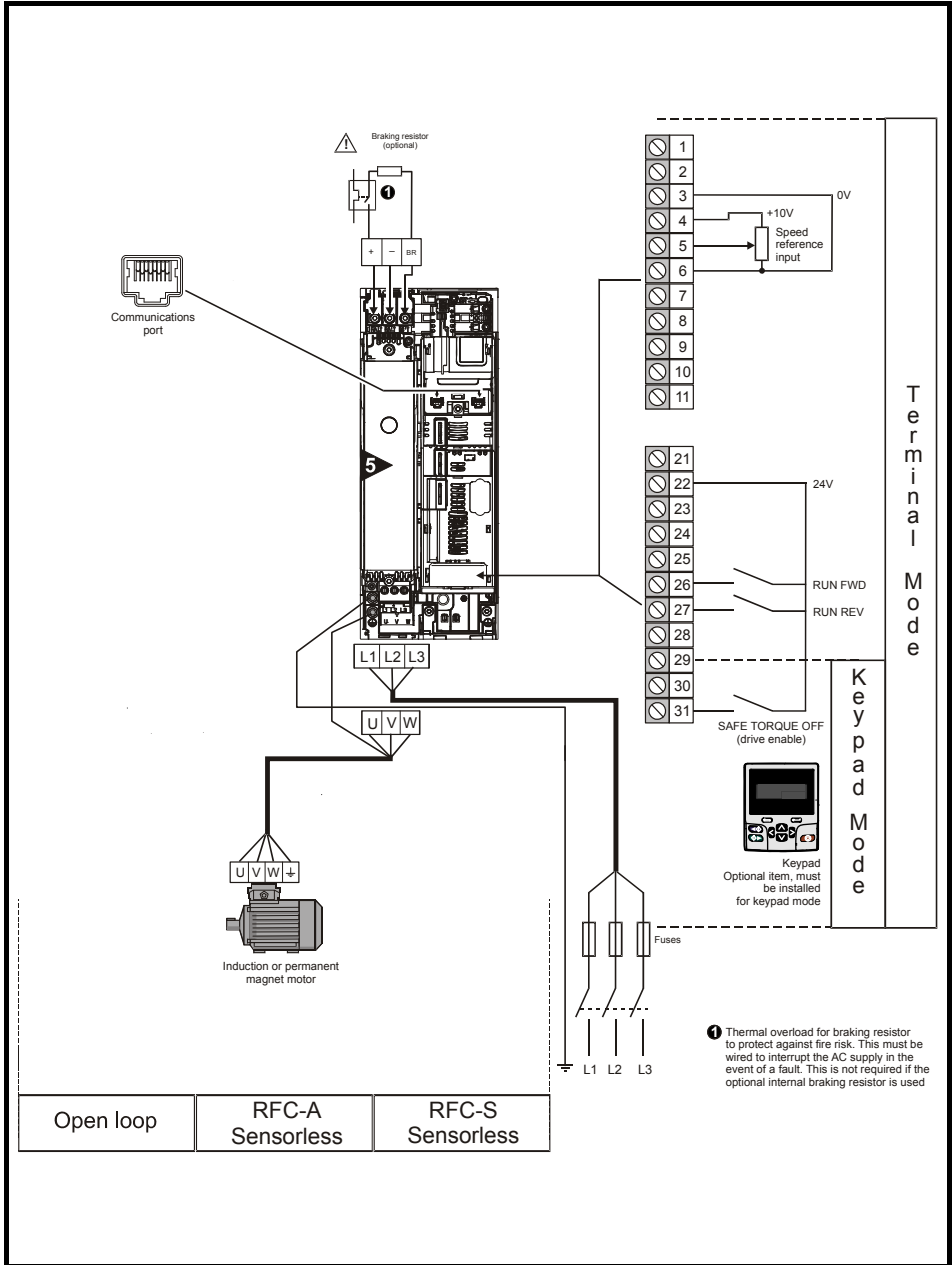
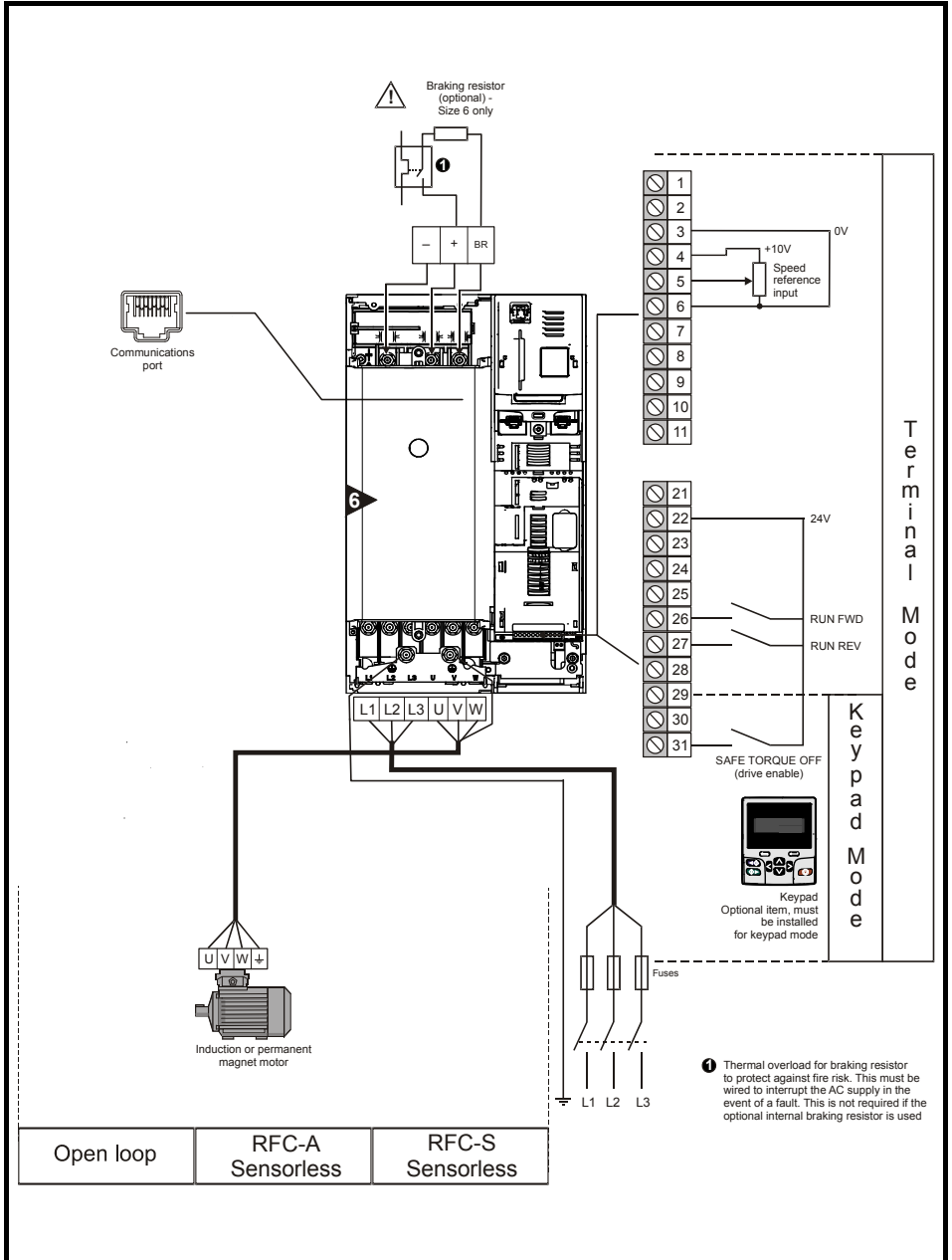
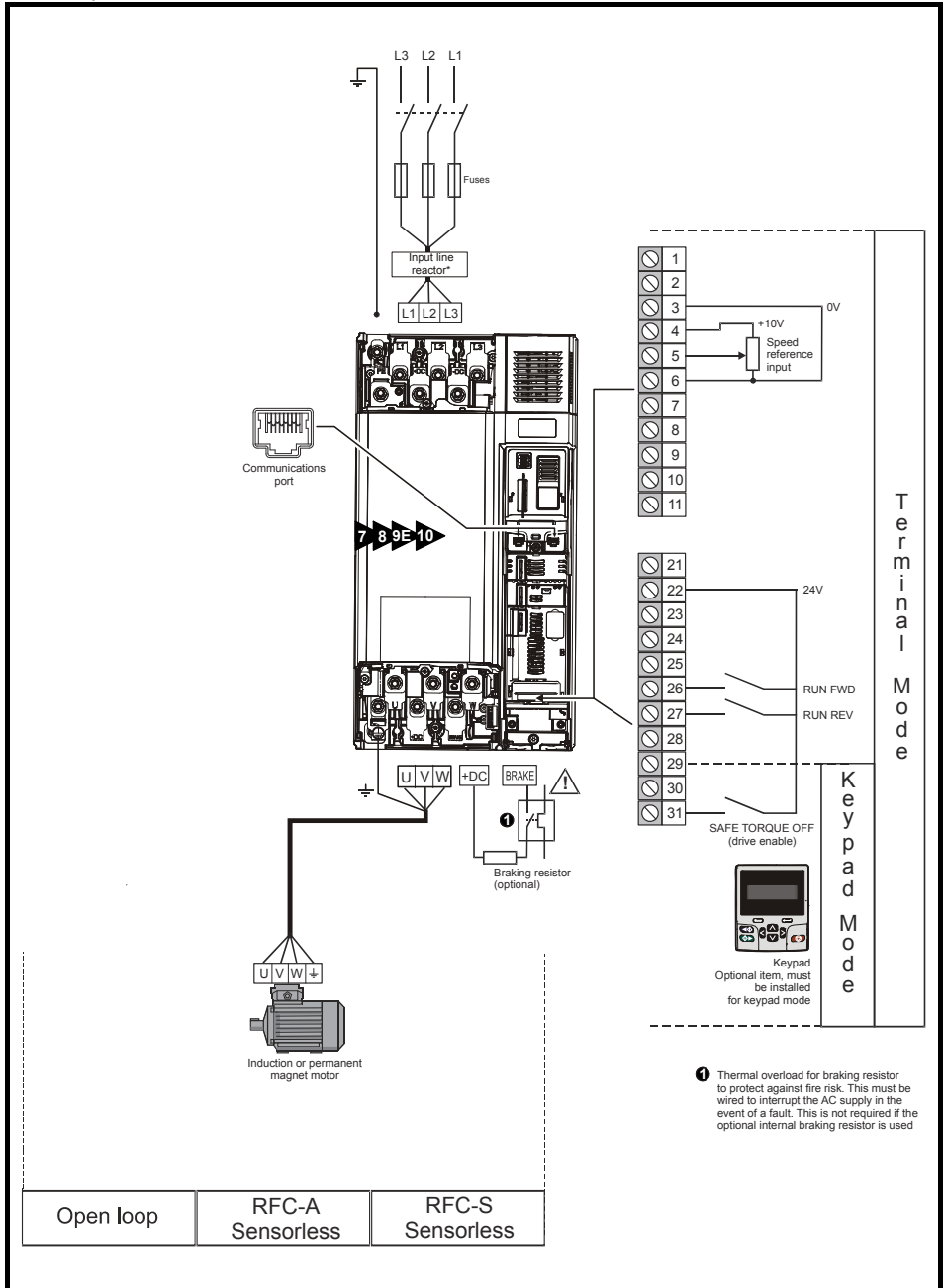

Figure 7-3 Minimum connections to get the motor running in any operating mode (size 6)



Safety information
Product information
Mechanical installation
Electrical installation
Getting started
Basic parameters
Running the motor
NV Media Card Operation
Further information



Figure 7-4 Minimum connections to get the motor running in any operating mode (size 7 onwards)



*Required for size 9E and 10.

7.2 Quick Start / start-up

7.2.1 Open loop

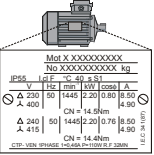
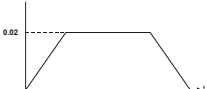
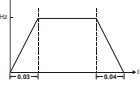
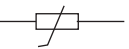
Action	Detail	
Before power-up	Ensure: <ul style="list-style-type: none"> The drive enable signal is not given (terminal 31) Run signal is not given Motor is connected 	
Power-up the drive	Verify that Open Loop mode is displayed as the drive powers up. If the mode is incorrect see section 5.6 <i>Changing the operating mode</i> on page 43 . Ensure that the drive displays 'Inhibit'	
Enter motor nameplate details	Enter: <ul style="list-style-type: none"> Motor rated frequency in Pr 00.047 (Hz) Motor rated current in Pr 00.046 (A) Motor rated speed in Pr 00.045 (rpm) Motor rated voltage in Pr 00.044 (V) - check if Δ or Y connection 	
Set maximum frequency	Enter: <ul style="list-style-type: none"> Maximum frequency in Pr 00.002 (Hz) 	
Set acceleration / deceleration rates	Enter: <ul style="list-style-type: none"> Acceleration rate in Pr 00.003 (s/100 Hz) Deceleration rate in Pr 00.004 (s/100 Hz) (If braking resistor installed, set Pr 00.015 = Fast. Also ensure Pr 10.030 and Pr 10.031 and Pr 10.061 are set correctly, otherwise premature 'Brake R Too Hot' trips may be seen). 	
Motor thermistor set-up	The motor thermistor can be selected in Pr 07.015 . Refer to Pr 07.015 for further information.	

Safety information

Product information

Mechanical installation

Electrical installation



Getting started

Basic parameters

Running the motor

NV Media Card Operation

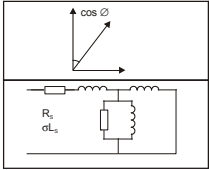





Further information

Action	Detail	
Autotune	<p>The drive is able to perform either a stationary or a rotating autotune. The motor must be at a standstill before an autotune is enabled. A rotating autotune should be used whenever possible so the measured value of power factor of the motor is used by the drive.</p> <div data-bbox="219 252 770 448" style="border: 1px solid black; padding: 5px;">  <p>WARNING</p> <p>A rotating autotune will cause the motor to accelerate up to $\frac{2}{3}$ base speed in the direction selected regardless of the reference provided. Once complete the motor will coast to a stop. The enable signal must be removed before the drive can be made to run at the required reference. The drive can be stopped at any time by removing the run signal or removing the drive enable.</p> </div> <ul style="list-style-type: none"> A stationary autotune can be used when the motor is loaded and it is not possible to uncouple the load from the motor shaft. A stationary autotune measures stator resistance and transient inductance of the motor and values relating to deadtime compensation from the drive. These are required for good performance in vector control modes. A stationary autotune does not measure the power factor of the motor so the value on the motor nameplate must be entered into Pr 00.043. A rotating autotune should only be used if the motor is uncoupled. A rotating autotune first performs a stationary autotune before rotating the motor at $\frac{2}{3}$ base speed in the direction selected. The rotating autotune measures the power factor of the motor. <p>To perform an autotune:</p> <ul style="list-style-type: none"> Set Pr 00.040 = 1 for a stationary autotune or set Pr 00.040 = 2 for a rotating autotune Close the Drive Enable signal (terminal 31). The drive will display 'Ready'. Close the run signal (terminal 26 or 27). The upper row of the display will flash 'Auto Tune' while the drive is performing the autotune. Wait for the drive to display 'Ready' or 'Inhibit' and for the motor to come to a standstill. Remove the drive enable and run signal from the drive. 	
Save parameters	<p>Select 'Save Parameters' in Pr mm.000 (alternatively enter a value of 1000 in Pr mm.000) and press the red  reset button or toggle the reset digital input.</p>	
Run	<p>Drive is now ready to run</p> 	

7.2.2 RFC-A mode (with position feedback)

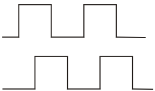
Induction motor with position feedback using optional SI-Encoder module

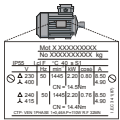
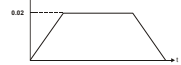
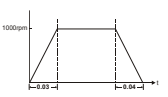
Only an incremental quadrature encoder as supported by the optional SI-Encoder module will be considered here.

Action	Detail	
Before power-up	Ensure: <ul style="list-style-type: none"> The drive enable signal is not given (terminal 31). Run signal is not given Motor and feedback device are connected 	
Power-up the drive	Verify that RFC-A mode is displayed as the drive powers up. If the mode is incorrect see section 5.6 <i>Changing the operating mode</i> on page 43, otherwise restore parameter defaults (see section 5.8 <i>Restoring parameter defaults</i> on page 44. Ensure that the drive displays 'Inhibit'	
Enable motor feedback and set parameters	Incremental encoder basic set-up Set Pr 03.024 = Feedback (0) Enter: <ul style="list-style-type: none"> Encoder power supply in Pr. mm.036 = 5 V (0), 8 V (1) or 15 V (2). * <p>NOTE</p> If output voltage from the encoder is >5 V, then the termination resistors must be disabled Pr mm.039 to 0. *	
	 <p>CAUTION</p> Setting the encoder voltage supply too high for the encoder could result in damage to the feedback device. <ul style="list-style-type: none"> Drive encoder Lines Per Revolution (LPR) in Pr mm.034 (set according to encoder) * Drive encoder termination resistor setting in Pr mm.039: * <ul style="list-style-type: none"> 0 = A-A\, B-B\ termination resistors disabled 1 = A-A\, B-B\, termination resistors enabled * mm is dependant on the slot into which the SI-Encoder module is installed (15 = Slot 1, 16 = Slot 2, 17 = Slot 3).	
Enter motor nameplate details	<ul style="list-style-type: none"> Motor rated frequency in Pr 00.047 (Hz) Motor rated current in Pr 00.046 (A) Motor rated speed in Pr 00.045 (rpm) Motor rated voltage in Pr 00.044 (V) - check if Δ or Δ connection 	
Set maximum speed	Enter: Maximum speed in Pr 00.002 (rpm)	
Set acceleration / deceleration rates	Enter: <ul style="list-style-type: none"> Acceleration rate in Pr 00.003 (s/1000 rpm) Deceleration rate in Pr 00.004 (s/1000 rpm) (If braking resistor installed, set Pr 00.015 = Fast. Also ensure Pr 10.030, Pr 10.031 and Pr 10.061 are set correctly, otherwise premature 'Brake R Too Hot' trips may be seen). 	
Motor thermistor set-up	The motor thermistor can be selected in Pr 07.015 . Refer to Pr 07.015 for further information.	

Safety information

Product information

Mechanical installation

Electrical installation



Getting started

Basic parameters

Running the motor



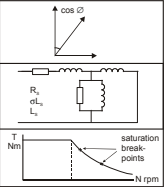

NV Media Card Operation

Further information

Action	Detail	
Autotune	<p>The drive is able to perform either a stationary or a rotating autotune. The motor must be at a standstill before an autotune is enabled. A stationary autotune will give moderate performance whereas a rotating autotune will give improved performance as it measures the actual values of the motor parameters required by the drive.</p> <div data-bbox="210 236 812 432" style="border: 1px solid black; padding: 5px;">  <p>WARNING A rotating autotune will cause the motor to accelerate up to $\frac{2}{3}$ base speed in the direction selected regardless of the reference provided. Once complete the motor will coast to a stop. The enable signal must be removed before the drive can be made to run at the required reference.</p> <p>The drive can be stopped at any time by removing the run signal or removing the drive enable.</p> </div> <ul style="list-style-type: none"> A stationary autotune can be used when the motor is loaded and it is not possible to uncouple the load from the motor shaft. The stationary autotune measures the stator resistance and transient inductance of the motor and values relating to deadtime compensation from the drive. Measured values are used to calculate the current loop gains, and at the end of the test the values in Pr 00.038 and Pr 00.039 are updated. A stationary autotune does not measure the power factor of the motor so the value on the motor nameplate must be entered into Pr 00.043. A rotating autotune should only be used if the motor is uncoupled. A rotating autotune first performs a stationary autotune before rotating the motor at $\frac{2}{3}$ base speed in the direction selected. The rotating autotune measures the stator inductance of the motor and calculates the power factor. <p>To perform an autotune:</p> <ul style="list-style-type: none"> Set Pr 00.040 = 1 for a stationary autotune or set Pr 00.040 = 2 for a rotating autotune Close the drive enable signal (terminal 31). The drive will display 'Ready'. Close the run signal (terminal 26 or 27). The upper row of the display will flash 'Auto Tune' while the drive is performing the autotune. Wait for the drive to display 'Ready' or 'Inhibit' and for the motor to come to a standstill Remove the drive enable and run signal from the drive. 	 <p>The diagram consists of two parts. The top part shows a vector diagram with a horizontal axis and a vertical axis. A vector labeled 'cos φ' is shown in the first quadrant. The bottom part is a circuit diagram showing a resistor labeled R_s, a series inductor labeled σL_s, and a parallel inductor labeled L_s. Below the circuit diagram is a graph showing torque T (Nm) on the vertical axis and speed N (rpm) on the horizontal axis. The graph shows a curve that starts at a high torque value and decreases as speed increases, with a vertical dashed line indicating a 'saturation break-point'.</p>
Save parameters	<p>Select 'Save Parameters' in Pr mm.000 (alternatively enter a value of 1000 in Pr mm.000) and press red  reset button or toggle the reset digital input.</p>	
Run	<p>Drive is now ready to run</p>	

7.2.3 RFC-A mode (Sensorless)

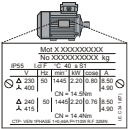
Induction motor with sensorless control

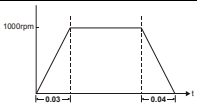
Action	Detail	
Before power-up	Ensure: <ul style="list-style-type: none"> The drive enable signal is not given (terminal 31) Run signal is not given Motor is connected 	
Power-up the drive	Verify that RFC-A mode is displayed as the drive powers up. If the mode is incorrect see section 5.6 <i>Changing the operating mode</i> on page 43, otherwise restore parameter defaults (see section 5.8 <i>Restoring parameter defaults</i> on page 44. Ensure that the drive displays 'Inhibit'	
Enter motor nameplate details	Enter: <ul style="list-style-type: none"> Motor rated frequency in Pr 00.047 (Hz) Motor rated current in Pr 00.046 (A) Motor rated speed in Pr 00.045 (rpm) Motor rated voltage in Pr 00.044 (V) - check if Δ or Δ connection 	
Set maximum speed	Enter: <ul style="list-style-type: none"> Maximum speed in Pr 00.002 (rpm) 	
Set acceleration / deceleration rates	Enter: <ul style="list-style-type: none"> Acceleration rate in Pr 00.003 (s/1000rpm) Deceleration rate in Pr 00.004 (s/1000rpm) (If braking resistor installed, set Pr 00.015 = FAST. Also ensure Pr 10.030, Pr 10.031 and Pr 10.061 are set correctly, otherwise premature 'Brake R Too Hot' trips may be seen). 	

Safety information

Product information

Mechanical installation

Electrical installation



Getting started

Basic parameters



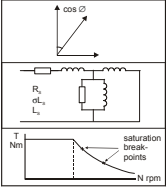

Running the motor

NV Media Card Operation

Further information

Action	Detail	
Autotune	<p>The drive is able to perform either a stationary or a rotating autotune. The motor must be at a standstill before an autotune is enabled. A stationary autotune will give moderate performance whereas a rotating autotune will give improved performance as it measures the actual values of the motor parameters required by the drive.</p> <p>NOTE It is highly recommended that a rotating autotune is performed (Pr 00.040 set to 2).</p> <div data-bbox="255 331 776 531" style="border: 1px solid black; padding: 5px;">  <p>A rotating autotune will cause the motor to accelerate up to $\frac{2}{3}$ base speed in the direction selected regardless of the reference provided. Once complete the motor will coast to a stop. The enable signal must be removed before the drive can be made to run at the required reference. The drive can be stopped at any time by removing the run signal or removing the drive enable.</p> </div> <ul style="list-style-type: none"> A stationary autotune can be used when the motor is loaded and it is not possible to uncouple the load from the motor shaft. The stationary autotune measures the stator resistance and transient inductance of the motor and values relating to deadtime compensation from the drive. Measured values are used to calculate the current loop gains, and at the end of the test the values in Pr 00.038 and Pr 00.039 are updated. A stationary autotune does not measure the power factor of the motor so the value on the motor nameplate must be entered into Pr 00.043. A rotating autotune should only be used if the motor is uncoupled. A rotating autotune first performs a stationary autotune before rotating the motor at $\frac{2}{3}$ base speed in the direction selected. The rotating autotune measures the stator inductance of the motor and calculates the power factor. <p>To perform an autotune:</p> <ul style="list-style-type: none"> Set Pr 00.040 = 1 for a stationary autotune or set Pr 00.040 = 2 for a rotating autotune Close the drive enable signal (terminal 31). The drive will display 'Ready' or 'Inhibit'. Close the run signal (terminal 26 or 27). The lower display will flash 'Autotune' while the drive is performing the autotune. Wait for the drive to display 'Ready' or 'Inhibit' and for the motor to come to a standstill. Remove the drive enable and run signal from the drive. 	
Save parameters	<p>Select 'Save Parameters' in Pr mm.000 (alternatively enter a value of 1000 in Pr mm.000) and press red  reset button or toggle the reset digital input.</p>	
Run	<p>Drive is now ready to run</p>	

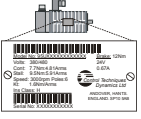
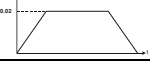
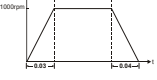
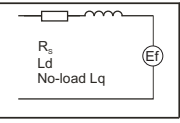
7.2.4 RFC-S mode (Sensorless) Permanent magnet motor without position feedback

Action	Detail	
Before power-up	Ensure: <ul style="list-style-type: none"> The drive enable signal is not given (terminal 31). Run signal is not given Motor is connected 	
Power-up the drive	Verify that RFC-S mode is displayed as the drive powers up. If the mode is incorrect see section 5.6 <i>Changing the operating mode</i> on page 43, otherwise restore parameter defaults (see section 5.8 <i>Restoring parameter defaults</i> on page 44). Ensure that the drive displays 'inhibit'	
Enter motor nameplate details	Enter: <ul style="list-style-type: none"> Motor rated current in Pr 00.046 (A) Ensure that this equal to or less than the Heavy Duty rating of the drive otherwise 'Motor Too Hot' trips may occur during the autotune. Number of poles in Pr 00.042 Motor rated voltage in Pr 00.044 (V) 	
Set maximum speed	Enter: <ul style="list-style-type: none"> Maximum speed in Pr 00.002 (rpm) 	
Set acceleration / deceleration rates	Enter: <ul style="list-style-type: none"> Acceleration rate in Pr 00.003 (s/1000 rpm) Deceleration rate in Pr 00.004 (s/1000 rpm) (If braking resistor installed, set Pr 00.015 = Fast. Also ensure Pr 10.030, Pr 10.031 and Pr 10.061 are set correctly, otherwise premature 'Brake R Too Hot' trips may be seen). 	
Autotune	The drive is able to perform a stationary autotune. The motor must be at a standstill before an autotune is enabled. A stationary autotune will give moderate performance. <ul style="list-style-type: none"> A stationary autotune is performed to locate the flux axis of the motor. The stationary autotune measures the stator resistance, inductance in flux axis, inductance in torque axis with no load on the motor and values relating to deadtime compensation from the drive. Measured values are used to calculate the current loop gains, and at the end of the test the values in Pr 00.038 and Pr 00.039 are updated. To perform an autotune: <ul style="list-style-type: none"> Set Pr 00.040 = 1 or 2 for a stationary autotune. (Both perform the same tests). Close the run signal (terminal 26 or 27). Close the drive enable signal (terminal 31). The upper row of the display will flash 'Auto Tune' during the test. Wait for the drive to display 'Ready' or 'Inhibit'. If the drive trips it cannot be reset until the drive enable signal (terminal 31) has been removed. <ul style="list-style-type: none"> Remove the drive enabled and run signal from the drive. 	
Check Saliency	In sensorless mode, when the motor speed is below Pr 00.045 / 10, a special low speed algorithm must be used to control the motor. There are two modes available, with the mode chosen based on the saliency of the motor. The ratio No-load Lq (Pr 00.056) / Ld (Pr 05.024) provides a measure of the saliency. If this value is > 1.1, then Non-salient mode must be used (this is the default), otherwise Injection mode may be used. Set Pr 00.054 for the selected mode: Injection (0) or Non-salient (1).	
Save parameters	Select 'Save Parameters' in Pr mm.000 (alternatively enter a value of 1000 in Pr mm.000) and press red  reset button or toggle the reset digital input.	
Run	Drive is now ready to run	

Safety information

Product information

Mechanical installation

Electrical installation

Getting started

Basic parameters

Running the motor

NV Media Card Operation

Further information

8 NV Media Card Operation

8.1 Introduction

The Non-Volatile Media Card feature enables simple configuration of parameters, parameter back-up and drive cloning using a SMARTCARD or SD card. The drive offers backward compatibility for a Unidrive SP SMARTCARD.

The NV Media Card can be used for:

- Parameter copying between drives
- Saving drive parameter sets
- Saving a program

The NV Media Card is located at the top of the module under the drive display (if installed) on the left-hand side.

Ensure NV Media Card is inserted with the contacts facing the left-hand side of the drive.

The drive only communicates with the NV Media Card when commanded to read or write, meaning the card may be "hot swapped".

Figure 8-1 Installation of the NV Media Card

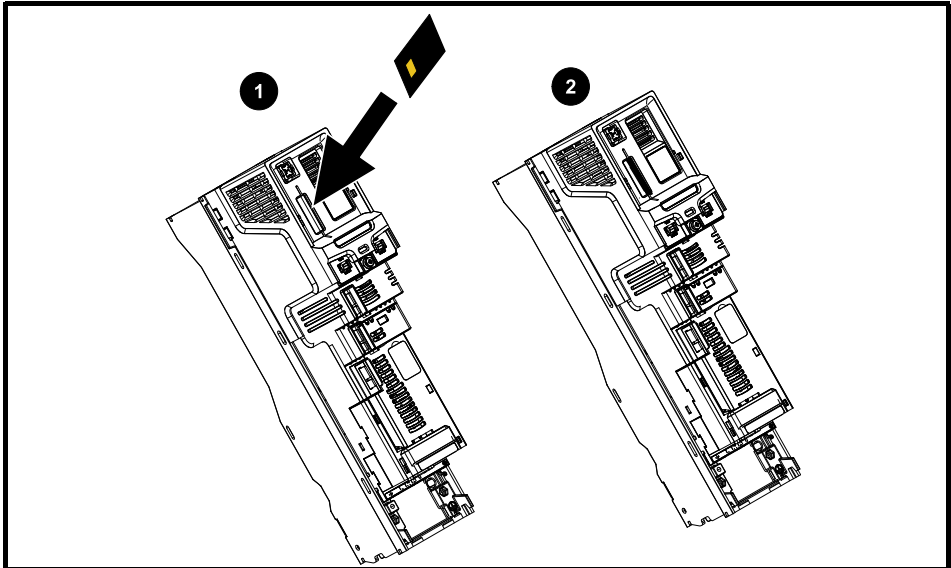

1. Installing the NV Media Card
2. NV Media Card installed

NV Media Card	Part number
SD Card Adaptor (memory card not included)	3130-1212-03
8 kB SMARTCARD	2214-4246-03
64 kB SMARTCARD	2214-1006-03

8.2 NV Media Card support

The NV Media Card can be used to store drive parameters and / or PLC programs set from the Unidrive M in data blocks 001 to 499.

The Unidrive M is compatible with a Unidrive SP SMARTCARD and is able to read and translate the Unidrive SP parameter set into a compatible parameter set for Unidrive M. This is only possible if the Unidrive SP parameter set was transferred to the SMARTCARD using the difference from defaults transfer method (i.e. 4yyy transfer). The Unidrive M is not able to read any other type of Unidrive SP data block on the card. Although it is possible to transfer difference from default data blocks from a Unidrive SP into the Unidrive M, the following should be noted:

1. If a parameter from the source drive does not exist in the target drive then no data is transferred for that parameter.
2. If the data for the parameter in the target drive is out of range then the data is limited to the range of the target parameter.
3. If the target drive has a different rating to the source drive then the normal rules for this type of transfer apply.

Figure 8-2 Basic NV Media Card operation

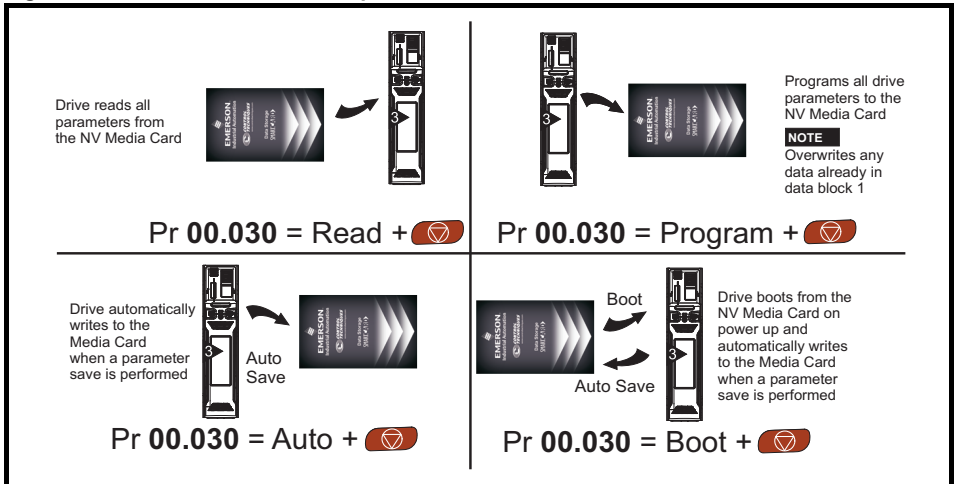

The whole card may be protected from writing or erasing by setting the read-only flag, refer to the *Drive User Guide* for further information.

The card should not be removed during data transfer, as the drive will produce a trip. If this occurs then either the transfer should be reattempted or in the case of a card to drive transfer, default parameters should be loaded.

8.3 Transferring data

Data transfer, erasing and protecting the information is performed by entering a code in Pr **mm.000** and then resetting the drive as shown in Table 8-1.

Table 8-1 SMARTCARD and SD card codes

Code	Operation	SMARTCARD	SD card
2001	Transfer the drive parameters to parameter file 001 and sets the block as bootable. This will include the parameters from attached option modules.	✓	✓
4yyy	Transfer the drive parameters to parameter file yyy. This will include the parameters from attached option modules.	✓	✓
5yyy	Transfer the onboard user program to onboard user program file yyy.	✓	✓
6yyy	Load the drive parameters from parameter file yyy or the onboard user program from onboard user program file yyy.	✓	✓
7yyy	Erase file yyy.	✓	✓
8yyy	Compare the data in the drive with file yyy. If the files are the same then Pr mm.000 (mm.000) is simply reset to 0 when the compare is complete. If the files are different a 'Card Compare' trip is initiated. All other NV media card trips also apply.	✓	✓
9555	Clear the warning suppression flag	✓	✓
9666	Set the warning suppression flag	✓	✓
9777	Clear the read-only flag	✓	✓
9888	Set the read-only flag	✓	✓
9999	Erase and format the NV media card	✓	
40yyy	Backup all drive data (parameter differences from defaults, an onboard user program, applications programs and miscellaneous option data), including the drive name; the store will occur to the </MCDf/driveyyy/> folder; if it does not exist, it will be created. Because the name is stored, this is a backup, rather than a clone. The command code will be cleared when all drive and option data have been saved.		✓
60yyy	Load all drive data (parameter differences from defaults, an onboard user program, applications programs and miscellaneous option data); the load will come from the </MCDf/driveyyy/> folder. The command code will not be cleared until the drive and all option data have been loaded.		✓

9 Further information

9.1 Diagnostics

For further information on diagnostics including trips and alarms, refer to the *Drive User Guide*.

Safety information

Product information

Mechanical
Installation

Electrical Installation

Getting started

Basic parameters

Running the motor

NV Media Card
Operation

Further Information

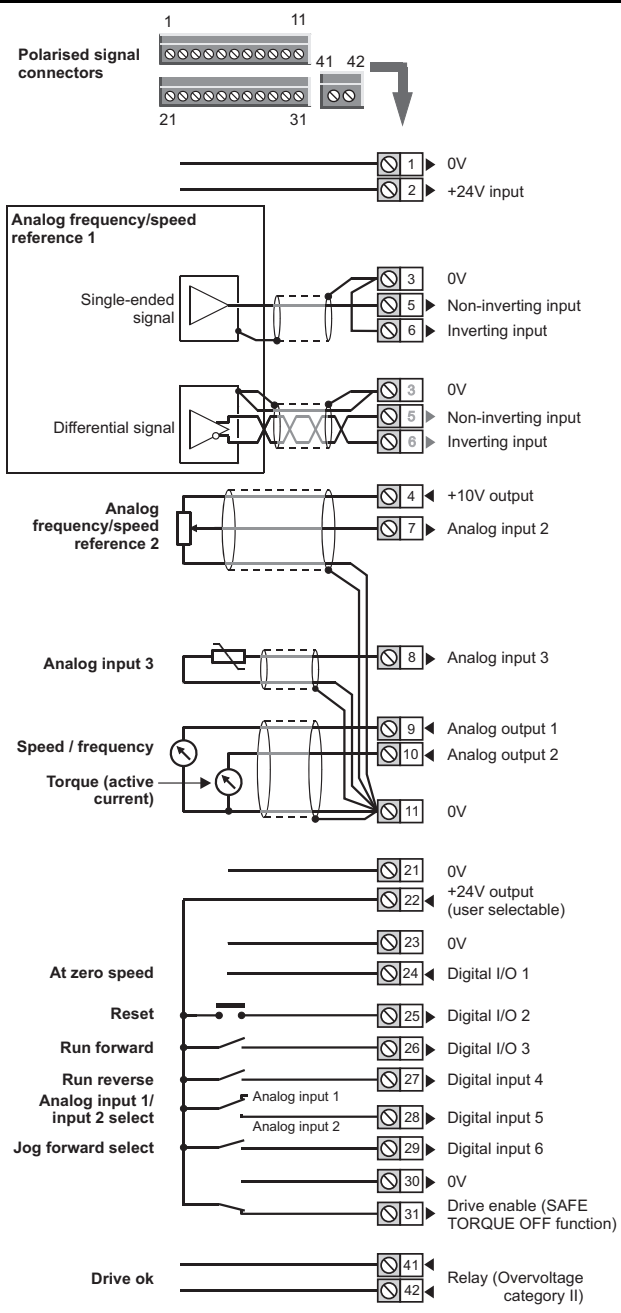

0478-0045-02