



## *Quick Start Guide*

---

# ***Unidrive M300***

---

*Frame sizes 1 to 4*

**Enhance throughput with  
Machine Safety**

Part Number: 0478-0039-05

Issue: 5

This guide is intended to provide basic information required in order to set-up a drive to run a motor. For more detailed installation information, please refer to the *Unidrive M300 User Guide* which is available to download from:

[www.controltechniques.com/userguides](http://www.controltechniques.com/userguides) or [www.emersonindustrial.com/en-EN/leroy-somer-motors-drives/downloads/Pages/manuals.aspx](http://www.emersonindustrial.com/en-EN/leroy-somer-motors-drives/downloads/Pages/manuals.aspx)

## Warnings, Cautions and Notes



A Warning contains information which is essential for avoiding a safety hazard.



A Caution contains information which is necessary for avoiding a risk of damage to the product or other equipment.

### **NOTE**

A **Note** contains information, which helps to ensure correct operation of the product.



This guide does not include safety information. Incorrect installation or operation of the drive, could cause personnel injury or equipment damage. For essential safety information, please refer to the *Unidrive M300 User Guide* or the safety booklet supplied with the drive.

---

# Contents

---

<b>1</b>	<b>Product information</b> .....	<b>7</b>
1.1	Ratings .....	7
<b>2</b>	<b>Options</b> .....	<b>8</b>
<b>3</b>	<b>Mechanical installation</b> .....	<b>9</b>
<b>4</b>	<b>Electrical installation</b> .....	<b>11</b>
4.1	AC supply requirements .....	11
4.2	External braking resistor .....	11
4.3	Ground leakage .....	12
4.4	Control terminal configurations and wiring .....	14
4.5	EMC .....	20
4.6	SAFE TORQUE OFF (STO) .....	21
<b>5</b>	<b>Keypad and display</b> .....	<b>22</b>
5.1	Saving parameters .....	23
5.2	Restoring parameter defaults .....	23
<b>6</b>	<b>Basic parameters (Menu 0)</b> .....	<b>24</b>
6.1	Menu 0: Basic parameters .....	24
<b>7</b>	<b>Running the motor</b> .....	<b>30</b>
<b>8</b>	<b>NV Media Card Operation</b> .....	<b>31</b>
<b>9</b>	<b>UL listing information</b> .....	<b>32</b>
9.1	General .....	32
9.2	Mounting .....	32
9.3	Environment .....	32
9.4	Electrical ratings .....	32
9.5	Opening of branch circuit .....	32
9.6	Electrical installation .....	32
9.7	cUL requirements for frame size 4 .....	33
9.8	Motor overload protection .....	33
9.9	Motor overspeed protection .....	33
9.10	Thermal memory retention .....	33
9.11	Group installation .....	34
9.12	UL listed accessories .....	34

# Declaration of Conformity

Control Techniques Ltd  
The Gro  
Newtown  
Powys  
UK  
SY16 3BE

Moteurs Leroy-Somer  
Usine des Agriers  
Boulevard Marcellin Leroy  
CS10015  
16915 Angoulême Cedex 9  
France

This declaration applies to Unidrive M variable speed drive products, comprising models numbers as shown below:

<b>Maaa-bbcdddd</b> Valid characters:	
<i>aaa</i>	100, 101, 200, 201, 300, 400
<i>bb</i>	01, 02, 03, 04, 05, 06, 07, 08
<i>c</i>	1, 2, 4, 5 or 6
<i>dddd</i>	00017, 00024, 00033, 00042 00013, 00018, 00023, 00024, 00032, 00033, 00041, 00042, 00056, 00075 00056, 00073, 00094, 00100 00133, 00135, 00170, 00176 00030, 00040, 00069, 00250, 00270, 00300 00100, 00150, 00190, 00230, 00290, 00330, 00350, 00420, 00440, 00470 00190, 00240, 00290, 00380, 00440, 00540, 00550, 00610, 00660, 00750, 00770, 00830, 01000 00630, 00860, 01160, 01320, 01340, 01570

The AC variable speed drive products listed above have been designed and manufactured in accordance with the following European harmonized standards:

EN 61800-5-1:2007	Adjustable speed electrical power drive systems - safety requirements - electrical, thermal and energy
EN 61800-3:2004	Adjustable speed electrical power drive systems. EMC product standard including specific test methods
EN 61000-6-2:2005	Electromagnetic compatibility (EMC). Generic standards. Immunity standard for industrial environments
EN 61000-6-4:2007	Electromagnetic compatibility (EMC). Generic standards. Emission standard for industrial environments
EN 61000-3-2:2006	Electromagnetic compatibility (EMC), Limits, Limits for harmonic current emissions (equipment input current <16 A per phase)
EN 61000-3-3:2008	Electromagnetic compatibility (EMC), Limits, Limitation of voltage fluctuations and flicker in low-voltage supply systems for equipment with rated current <16 A

EN 61000-3-2:2006 Applicable where input current <16 A. No limits apply for professional equipment where input power >1 kW.

These products comply with the Low Voltage Directive 2006/95/EC, the Electromagnetic Compatibility Directive 2004/108/EC.



**T. Alexander**  
**VP Technology**  
**Date: 29th May 2014**  
**Place: Newtown, Powys. UK**

**These electronic drive products are intended to be used with appropriate motors, controllers, electrical protection components and other equipment to form complete end products or systems. Compliance with safety and EMC regulations depends upon installing and configuring drives correctly, including using the specified input filters. The drives must be installed only by professional assemblers who are familiar with requirements for safety and EMC. The assembler is responsible for ensuring that the end product or system complies with all the relevant laws in the country where it is to be used. Refer to the User Guide. An EMC Data Sheet is also available giving detailed EMC information.**

## Declaration of Conformity (including 2006 Machinery Directive)

This declaration applies to Unidrive M variable speed drive products, comprising models numbers as shown below:

<b>Maaa-bbbbbbbb</b> Valid characters:	
<b>aaa</b>	300, 400
<b>bbbbbbbb</b>	01100017A, 01100024A, 01200017A, 01200024A, 01200033A, 01200042 02100042A, 02100056A, 02200024A, 02200033A, 02200042A, 02200056A, 02200075A, 02400013A, 02400018A, 02400023A, 02400032A, 02400041A  03200100A, 03400056A, 03400073A, 03400094A  04200133A, 04200176A, 04400135A, 04400170A  05200250A, 05400270A, 05400300A, 05500030A, 05500040A, 05500069A 06200330A, 06200440A, 06400350A, 06400420A, 06400470A, 06500100A, 06500150A, 06500190A, 06500230A, 06500290A, 06500350A  07200610A, 07200750A, 07200830A, 07400660A, 07400770A, 07401000A, 07500440A, 07500550A, 07600190A, 07600240A, 07600290A, 07600380A, 07600440A, 07600540A  08201160A, 08201320A, 08401340A, 08401570A, 08500630A, 08500860A, 08600630A, 08600860A

**This declaration relates to these products when used as a safety component of a machine. Only the SAFE TORQUE OFF function may be used for a safety function of a machine. None of the other functions of the drive may be used to carry out a safety function.**

These products fulfil all the relevant provisions of Directive 2006/42/EC (The Machinery Directive).

EC type-examination has been carried out by the following notified body:

TÜV Rheinland Industrie Service GmbH

Alboinstraße 56

12103 Berlin, Germany

Notified Body identification number: 0035

EC type-examination certificate number: 01/205/5383.00/14 and 01/205/5387.00/14

The harmonised standards used are shown below:

EN 61800-5-1:2007	Adjustable speed electrical power drive systems. Safety requirements. Electrical, thermal and energy
EN 61800-5-2:2007	Adjustable speed electrical power drive systems. Safety requirements. Functional
EN ISO 13849-1:2008	Safety of machinery. Safety-related parts of control systems. General principles for design
EN ISO 13849-2:2008	Safety of machinery. Safety-related parts of control systems. Validation
EN 62061:2005	Safety of machinery. Functional safety of safety related electrical, electronic and programmable electronic control systems

Person authorised to compile the technical file:

C Hargis  
Chief Engineer  
Newtown, Powys. UK



**T. Alexander**  
VP Technology  
Date: 9th April 2014  
Place: Newtown, Powys. UK

#### IMPORTANT NOTICE

These drive products are intended to be used with appropriate motors, sensors, electrical protection components and other equipment to form complete systems. It is the responsibility of the installer to ensure that the design of the complete machine, including its safety-related control system, is carried out in accordance with the requirements of the Machinery Directive and any other relevant legislation. The use of a safety-related drive in itself does not ensure the safety of the machine.

Compliance with safety and EMC regulations depends upon installing and configuring inverters correctly. The inverters must be installed only by professional assemblers who are familiar with requirements for safety and EMC. The assembler is responsible for ensuring that the end product or system complies with all the relevant laws in the country where it is to be used. Refer to the User Guide.

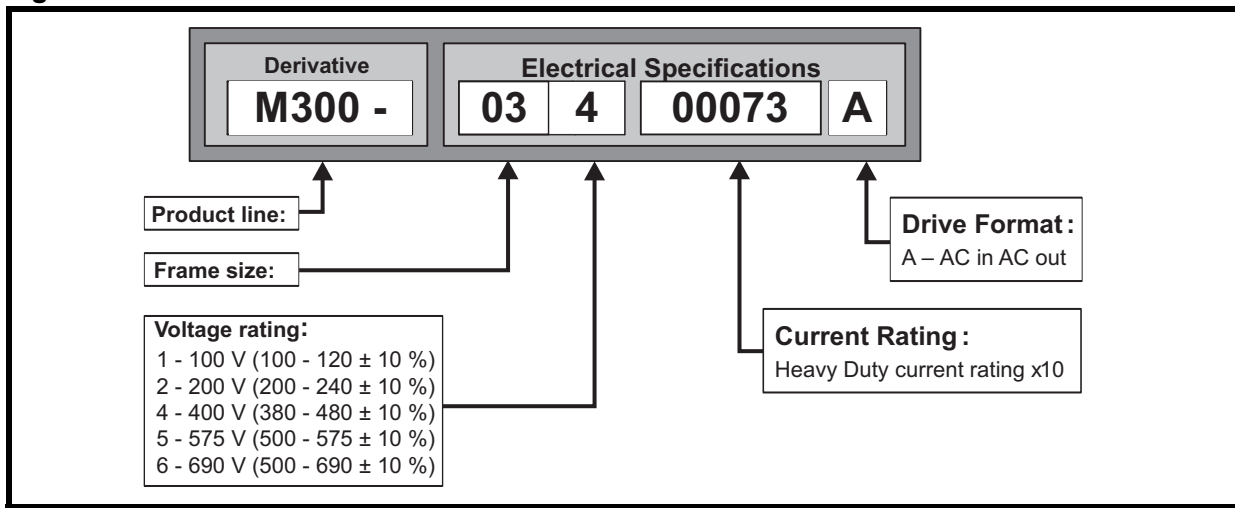
# 1 Product information

## 1.1 Ratings

Model	Input phases  ph	Max. cont input current  A	Max input fuse rating		Nominal cable size				Output current		
			1 Ph	3 Ph	European		USA		Max. cont output current  A	Nominal power  kW	Motor power  hp
					Input  mm <sup>2</sup>	Output  mm <sup>2</sup>	Input  AWG	Output  AWG			
01100017	1	8.7	10		1	1	16	16	1.7	0.25	0.33
01100024	1	11.1	16		1	1	14	16	2.4	0.37	0.5
01200017	1	4.5	6		1	1	16	16	1.7	0.25	0.33
01200024	1	5.3	6		1	1	16	16	2.4	0.37	0.5
01200033	1	8.3	10		1	1	16	16	3.3	0.55	0.75
01200042	1	10.4	16		1	1	16	16	4.2	0.75	1
02100042	1	18.8	20		2.5	1	12	16	4.2	0.75	1
02100056	1	24	25		4	1	10	16	5.6	1.1	1.5
02200024	1 / 3	5.3/4.1	6	6	1	1	16	16	2.4	0.37	0.5
02200033	1 / 3	8.3/6.7	10	10	1	1	16	16	3.3	0.55	0.75
02200042	1 / 3	10.4/7.5	16	10	1	1	16	16	4.2	0.75	1
02200056	1 / 3	14.9/11.3	20	15	2.5/1.5	1	12/14	16	5.6	1.1	1.5
02200075	1 / 3	18.1/13.5	20	15	2.5	1	12	16	7.5	1.5	2
02400013	3	2.4		6	1	1	16	16	1.3	0.37	0.5
02400018	3	2.9		6	1	1	16	16	1.8	0.55	0.75
02400023	3	3.5		6	1	1	16	16	2.3	0.75	1
02400032	3	5.1		6	1	1	16	16	3.2	1.1	1.5
02400041	3	6.2		10	1	1	16	16	4.1	1.5	2
03200100	1 / 3	23.9/17.7	25	20	4	1.5	10/12	14	10	2.2	3
03400056	3	8.7		10	1	1	14	16	5.6	2.2	3
03400073	3	12.2		16	1.5	1	12	16	7.3	3	3
03400094	3	14.8		16	2.5	1.5	12	14	9.4	4	5
04200133	1 / 3	23.7/16.9	25	20	4/2.5	2.5	10	12	13.3	3	3
04200176	3	21.3		25	4	2.5	10	12	17.6	4	5
04400135	3	16.3		20	2.5	2.5	10	12	13.5	5.5	7.5
04400170	3	20.7		25	4	2.5	10	12	17	7.5	10







**NOTE** The nominal cable sizes shown in the table above, are provided as a guide only. Ensure that the cables used conform to the local wiring regulations.

Figure 1-1 Model number structure



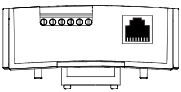
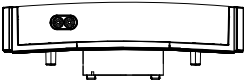
## 2 Options

Table 2-1 System Integration (SI) option module identification

Type	Option module	Color	Name	Further details
Fieldbus		Purple	SI-PROFIBUS	See relevant option module User Guide
		Medium Grey	SI-DeviceNet	
		Light Grey	SI-CANopen	
		Beige	SI-Ethernet	
		Brown Red	SI-EtherCAT	
Automation (I/O expansion)		Orange	SI-I/O	

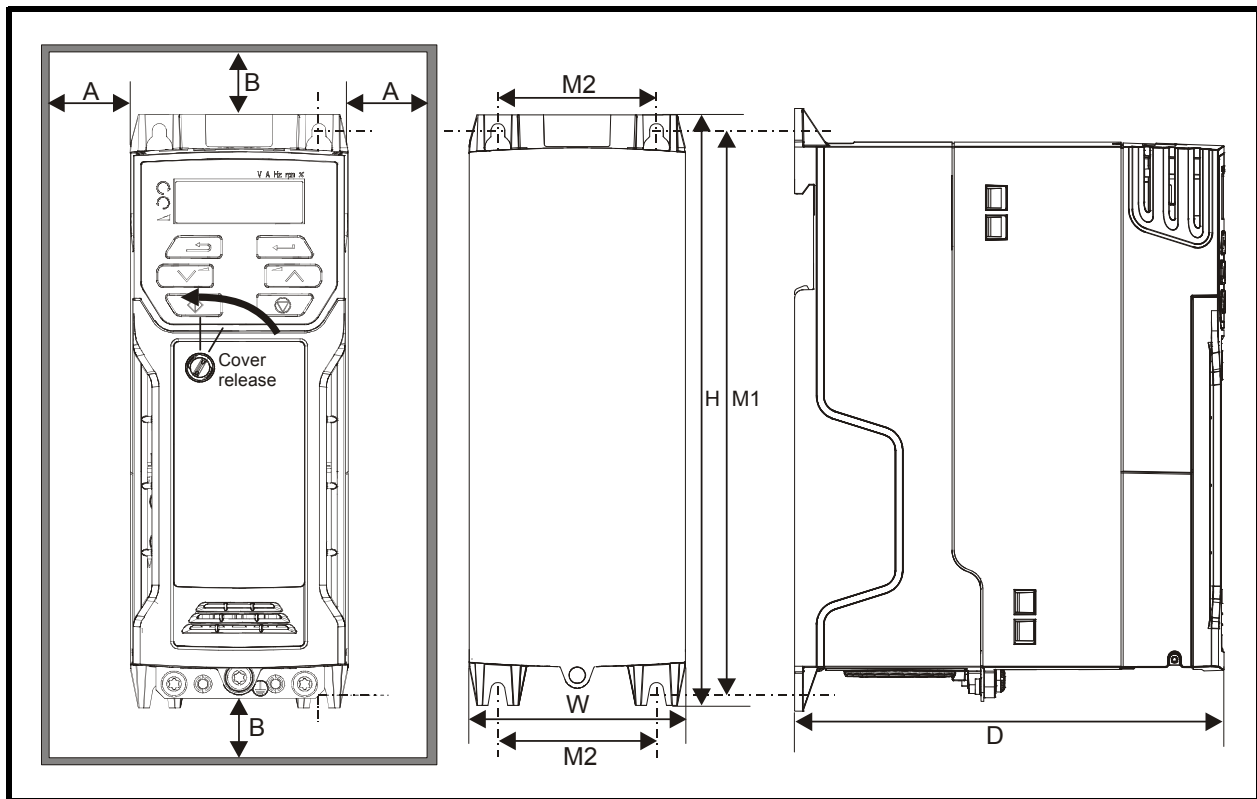


**Table 2-2 Adaptor Interface (AI) option module identification**

Type	Option module	Name	Further Details
Communications		AI-485 Adaptor	See <i>Drive User Guide</i>
Backup		AI-Backup Adaptor	

### 3 Mechanical installation

The drives can be panel mounted with 0 mm space between the drives. For further information on mechanical installation refer to the *Drive User Guide*.



To remove the terminal cover, use a flat bladed screwdriver to rotate the terminal cover locating clip by approximately 30° in a counter clockwise direction, and then slide the cover down.

Drive Size	H		W		D		M1		M2		Ø		A		B	
	mm	in	mm	in	mm	in	mm	in	mm	in	mm	in	mm	in	mm	in
1	160	6.30	75	2.95	130	5.12	143	5.70	53	2.08	5	0.2	0.00	0.00	100	3.93
2	205	8.07	78	3.07	150	5.91	194	7.63	55	2.17	5	0.2				
3	226	8.90	90	3.54	160	6.30	215	8.46	70.7	2.80	5	0.2				
4	277	10.91	115	4.53	175	6.89	265	10.43	86	3.40	6	0.23				

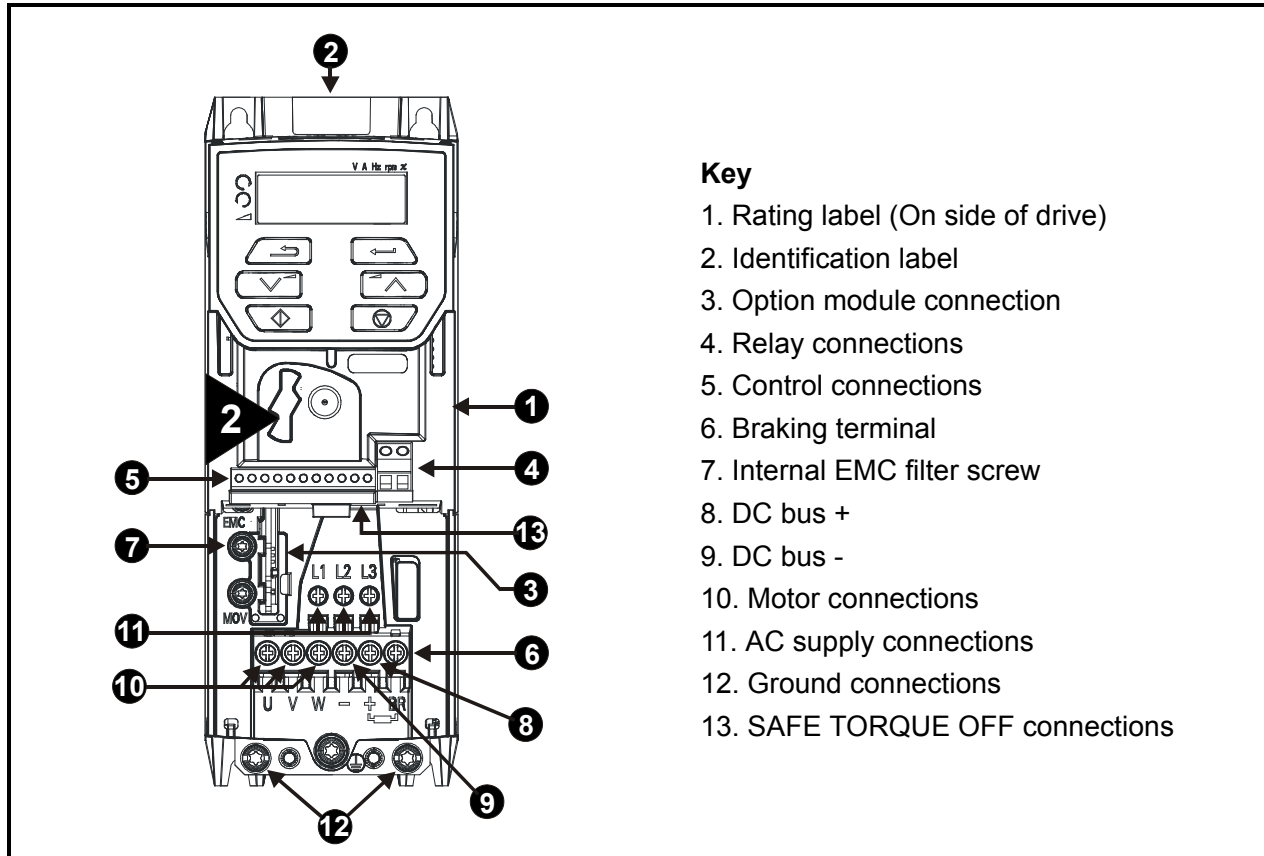
**Table 3-1 Tools required**

Tool	Location	Size 1	Size 2	Size 3	Size 4
Small terminal screwdriver	Control, relay and STO terminals	✓	✓	✓	✓
3mm Flat-bladed screwdriver	Power terminals	✓			
5mm Flat-bladed screwdriver	Terminal cover	✓	✓	✓	✓
Pozidrive 1 screwdriver	AC power terminals		✓		
Pozidrive 2 screwdriver	Power terminals		✓	✓	✓
Torx 10 driver	EMC & MOV screws	✓	✓	✓	✓
Torx 15 driver	Fan screw	✓			
Torx 20 driver	Fan screw		✓	✓	✓

**Table 3-2 Recommended torque settings**

Model size	Terminal block description	Torque settings
All	Control terminals	0.2 N m (0.15 lb ft)
	Relay terminals	0.5 N m (0.37 lb ft)
1	Power terminals	0.5 N m (0.37 lb ft)
2, 3, 4		1.4 N m (1.03 lb ft)

**Figure 3-1 Feature diagram (size 2 shown)**



## 4 Electrical installation

An overlay of the electrical connections / terminals is included on the back page of this manual.

### 4.1 AC supply requirements

Voltage:

100 V drive: 100 V to 120 V  $\pm 10$  %

200 V drive: 200 V to 240 V  $\pm 10$  %

400 V drive: 380 V to 480 V  $\pm 10$  %

Number of phases: 3

Maximum supply imbalance: 2 % negative phase sequence (equivalent to 3 % voltage imbalance between phases).

Frequency range: 48 to 62 Hz

For UL compliance only, the maximum supply symmetrical fault current must be limited to 100 kA.

#### NOTE

On the size 2 110 V drives or when connecting single phase to a dual rated 200 V unit, the supply should be connected to L1 and L3.

### 4.2 External braking resistor



#### Overload protection

When an external braking resistor is used, it is essential that an overload protection device is incorporated in the braking resistor circuit; as shown in the electrical diagram on the back cover.

#### 4.2.1 Minimum resistance values and peak power rating for the braking resistor at 40 °C (104 °F)

Table 4-1 Braking resistor resistance and power rating (100 V)

Model	Minimum resistance* $\Omega$	Instantaneous power rating kW	Continuous power rating kW
01100017	130	1.2	0.25
01100024			0.37
02100042	68	2.2	0.75
02100056			1.1

**Table 4-2 Braking resistor resistance and power rating (200 V)**

Model	Minimum resistance* Ω	Instantaneous power rating kW	Continuous power rating kW
01200017	130	1.2	0.25
01200024			0.37
01200033			0.55
01200042			0.75
02200024	68	2.2	0.37
02200033			0.55
02200042			0.75
02200056			1.1
02200075			1.5
03200100	45	3.4	2.2
04200133	22	6.9	3.0
04200176			4.0

**Table 4-3 Braking resistor resistance and power rating (400 V)**

Model	Minimum resistance* Ω	Instantaneous power rating kW	Continuous power rating kW
02400013	270	2.3	0.37
02400018			0.55
02400023			0.75
02400032			1.1
02400041			1.5
03400056	100	6.1	2.2
03400073			3
03400094			4
04400135	50	12.2	5.5
04400170			7.5

\* Resistor tolerance: ±10 %

### 4.3 Ground leakage

The ground leakage current depends upon whether the internal EMC filter is installed or not. The drive is supplied with the filter installed. Instructions for removing the internal filter are given in section 4.5.1 *Internal EMC filter* on page 20.

With internal filter installed:

**Size 1:**

- 2.5 mA\* AC at 230 V 50 Hz (line to line supply, star point ground)
- 9.2 mA\* AC at 230 V 50 Hz (line to neutral supply, star point ground)

**Size 2:**

- 9.36 mA\* AC at 110 V, 50 Hz (2 phase, line to line supply, star point ground)
- 16.4 mA\* AC at 110 V, 50 Hz (1 phase, line to neutral supply, star point ground)
- 5.3 mA\* AC at 230 V, 50 Hz (3 phase supply, star point ground)

15.4 mA\* AC at 230 V, 50 Hz (1 phase, line to neutral supply, star point ground)  
9.6 mA\* AC at 400 V, 50 Hz (3 phase supply, star point ground)

**Size 3:**

19.7 mA\* AC at 400 V 50 Hz (star point ground)  
47.4 mA\* AC at 400 V 50 Hz (corner ground)

**Size 4:**

21 mA\* AC at 230 V 50 Hz (3 phase, star point ground)  
6.8 mA\* AC at 230 V 50 Hz (1 phase, line to line supply, star point ground)  
30 mA\* AC at 230 V 50 Hz (1 phase, line to neutral supply, star point ground)  
50 mA\* AC at 400 V 50 Hz (3 phase, star point ground)

\*Proportional to the supply voltage and frequency.

With internal filter removed:

**Size 1:** <1.5 mA (line to line supply, star point ground)

<1 mA (line to neutral supply, star point ground)

**Size 2:** <1.7 mA (line to line supply, star point ground)

<1.9 mA (line to neutral supply, star point ground)

**Size 3:** <3.3 mA (star point ground)

<4.9 mA (corner ground)

**Size 4:** < 3.5 mA (star point ground)

**NOTE**

The above leakage currents are just the leakage currents of the drive with the internal EMC filter connected and do not take into account any leakage currents of the motor or motor cable.



**WARNING**

When the internal filter is installed the leakage current is high. In this case a permanent fixed ground connection must be provided, or other suitable measures taken to prevent a safety hazard occurring if the connection is lost.



**WARNING**

When the leakage current exceeds 3.5 mA, a permanent fixed ground connection must be provided using two independent conductors each with a cross-section equal to or exceeding that of the supply conductors. The drive is provided with two ground connections to facilitate this. Both ground connections are necessary to meet EN 61800-5-1: 2007.

### 4.3.1 Use of residual current device (RCD)

There are three common types of ELCB / RCD:

1. AC - detects AC fault currents
2. A - detects AC and pulsating DC fault currents (provided the DC current reaches zero at least once every half cycle)
3. B - detects AC, pulsating DC and smooth DC fault currents
  - Type AC should never be used with drives.
  - Type A can only be used with single phase drives
  - Type B must be used with three phase drives



**WARNING**

Only type B ELCB / RCD are suitable for use with 3 phase inverter drives.

If an external EMC filter is used, a delay of at least 50 ms should be incorporated to ensure spurious trips are not seen. The leakage current is likely to exceed the trip level if all of the phases are not energized simultaneously.

## 4.4 Control terminal configurations and wiring

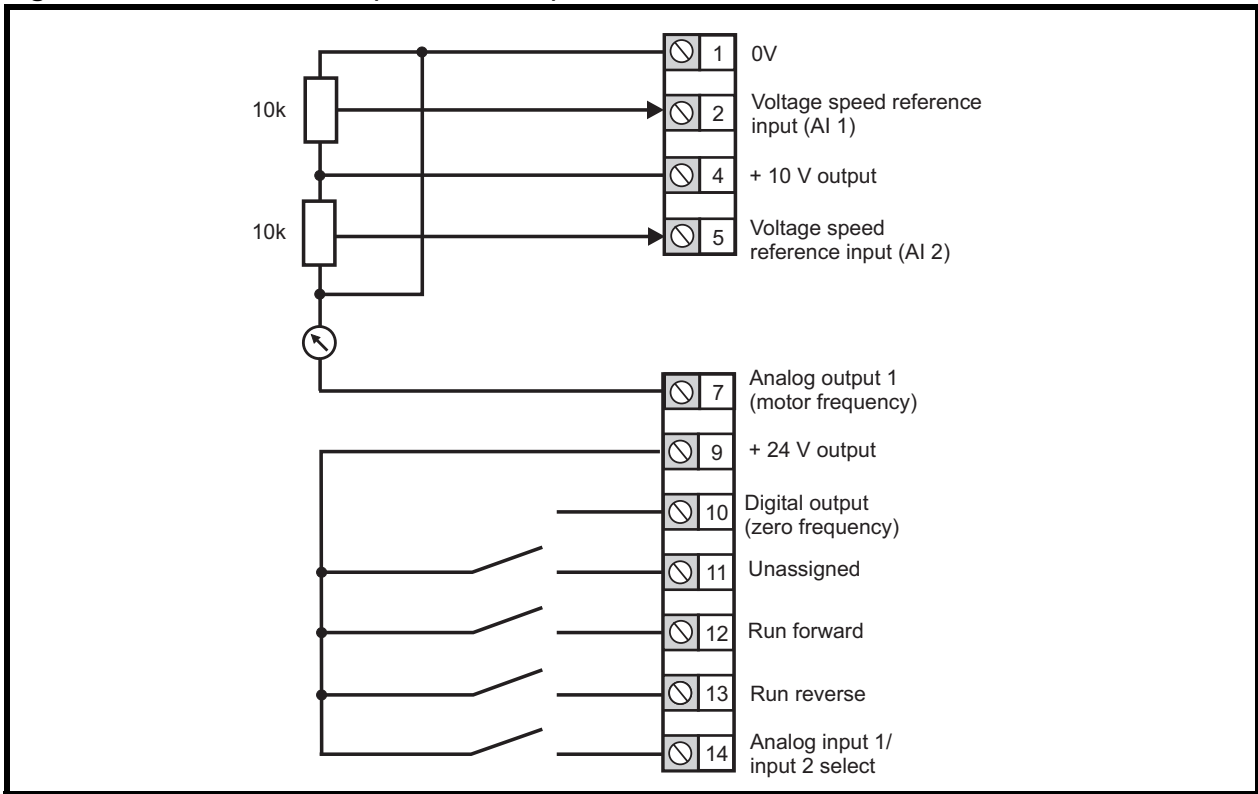
00.005		Drive Configuration								
RW	Txt						PT	US		
OL	↕	AV (0), AI (1), AV.Pr (2), AI.Pr (3), Preset (4), Pad (5), Pad.Ref (6), E.Pot (7), torque (8), Pid (9)				⇒	AV (0)			
RFC-A										

Value	Text	Description
0	AV	Analog input 1 (voltage) Analog input 2 (voltage) selected by terminal (Local/Remote)
1	AI	Analog input 1 (current) or Analog input 2 (voltage) selected by terminal (Local/Remote)
2	AV.Pr	Analog input 1 (voltage) or 3 presets selected by terminal
3	AI.Pr	Analog input 1 (current) or 3 presets selected by terminal
4	Preset	Four presets selected by terminal
5	Pad	Keypad reference
6	Pad.Ref	Keypad reference with terminal control
7	E.Pot	Electronic Potentiometer
8	torque	Torque mode, Analog input 1 (current frequency reference) or Analog input 2 (voltage torque reference) selected by terminal
9	Pid	PID mode, Analog input 1 (current feedback source) and Analog input 2 (voltage reference source)

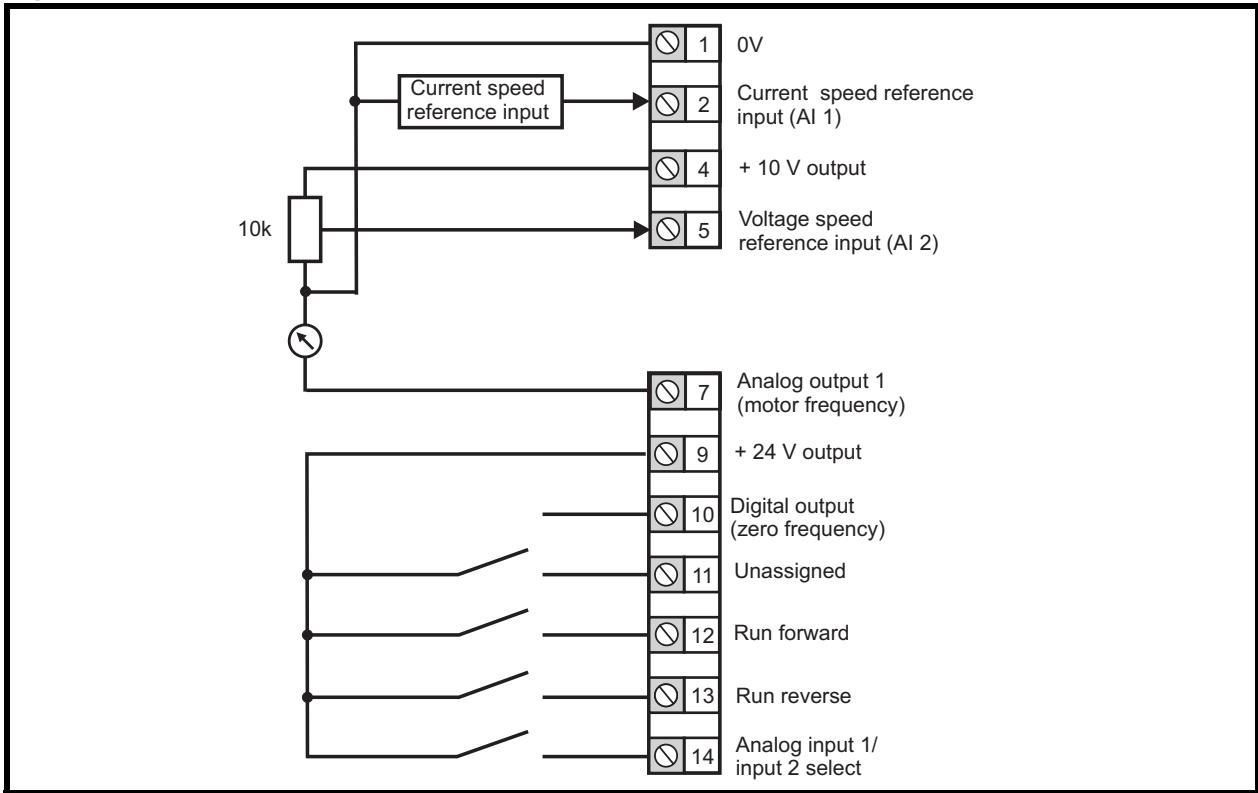
This parameter is used to automatically setup the user programmable area in the level 2 parameter set according to drive configurations. Other default values may also be changed by drive configuration. Parameters are stored in EEPROM automatically following a configuration change. Defaults are loaded before drive configuration changes are made. Defaults loaded are defined by *Defaults Previously Loaded* (11.046).

Action will only occur if the drive is inactive, not in UU state and no User Actions are running. Otherwise, the parameter will return to its pre altered value on exit from edit mode. All parameters are saved if this parameter changes.

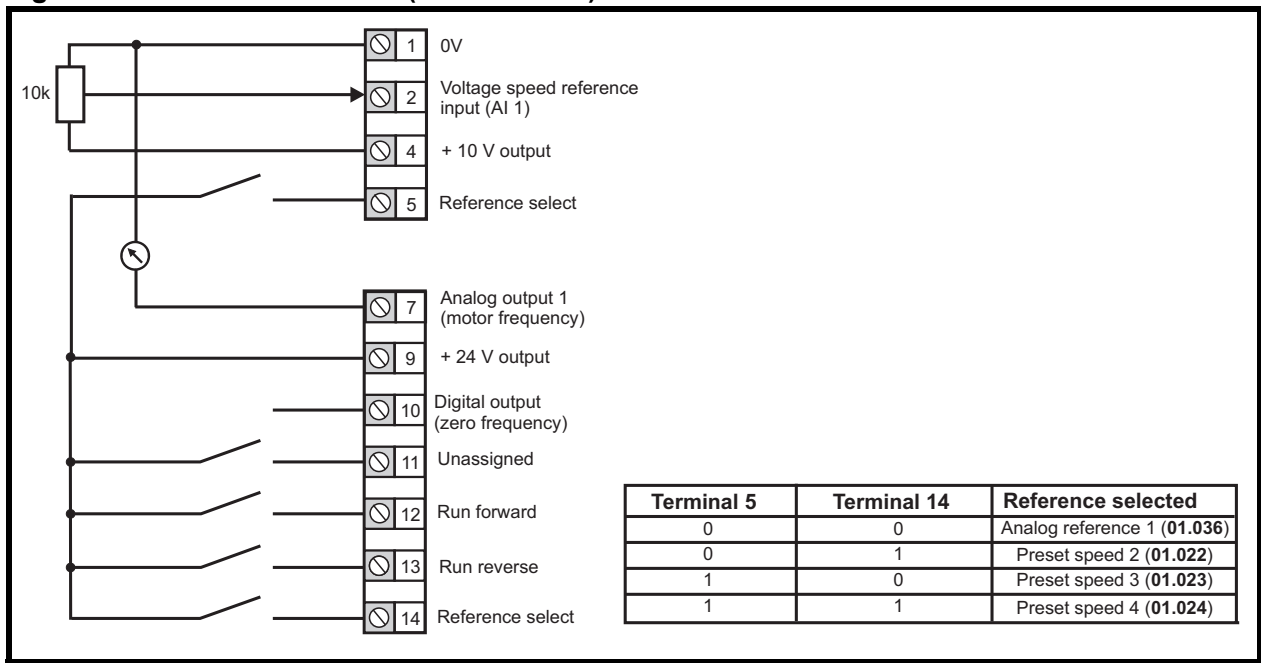
**Figure 4-1 Pr 00.005 = AV (50 and 60 Hz)**



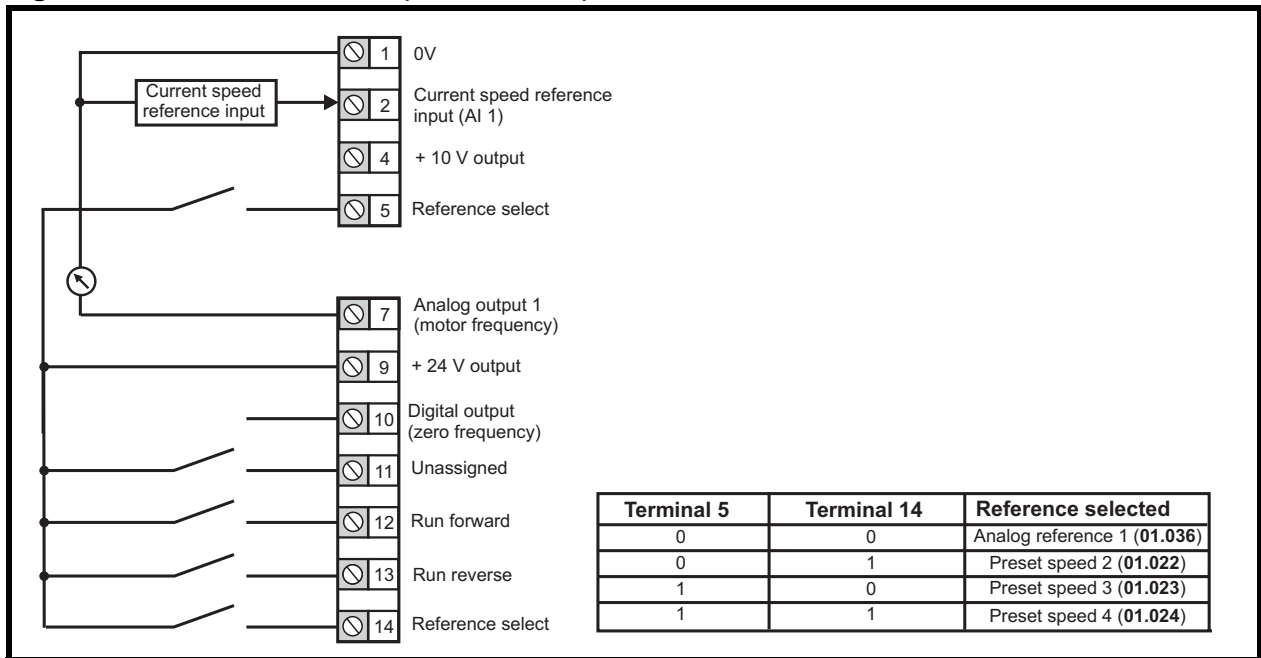
**Figure 4-2 Pr 00.005 = AI (50 and 60 Hz)**



**Figure 4-3 Pr 00.005 = AV.Pr (50 and 60 Hz)**

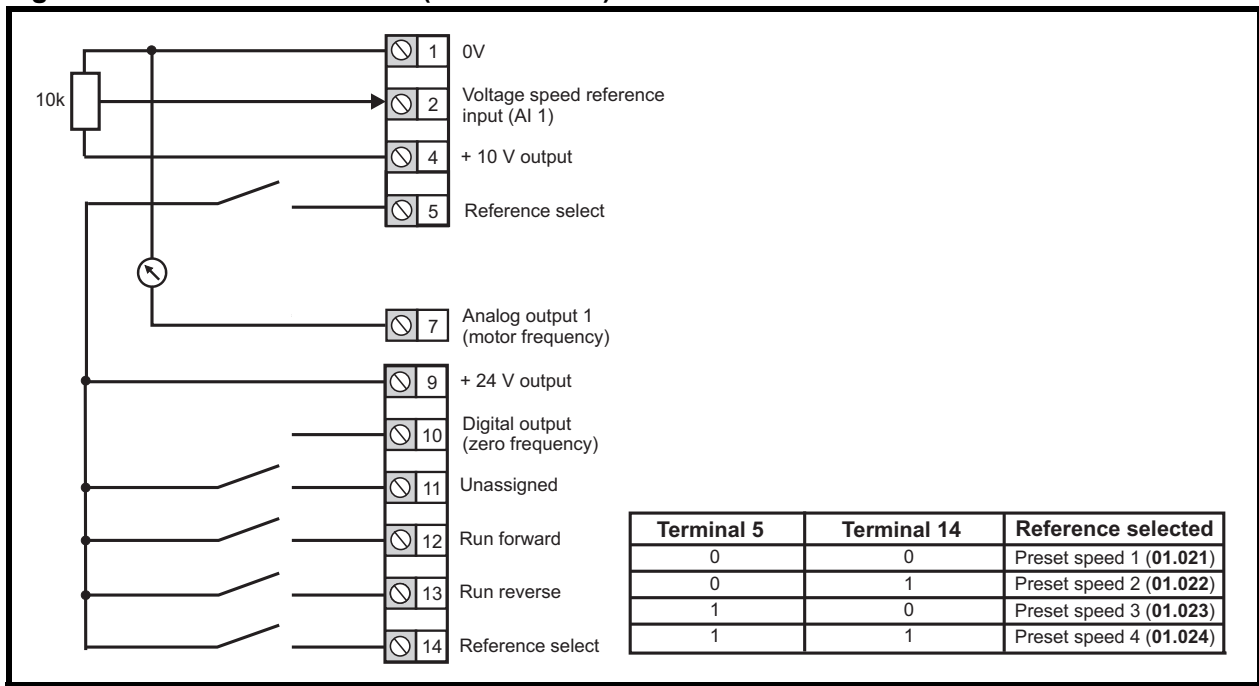


**Figure 4-4 Pr 00.005 = AI.Pr (50 and 60 Hz)**

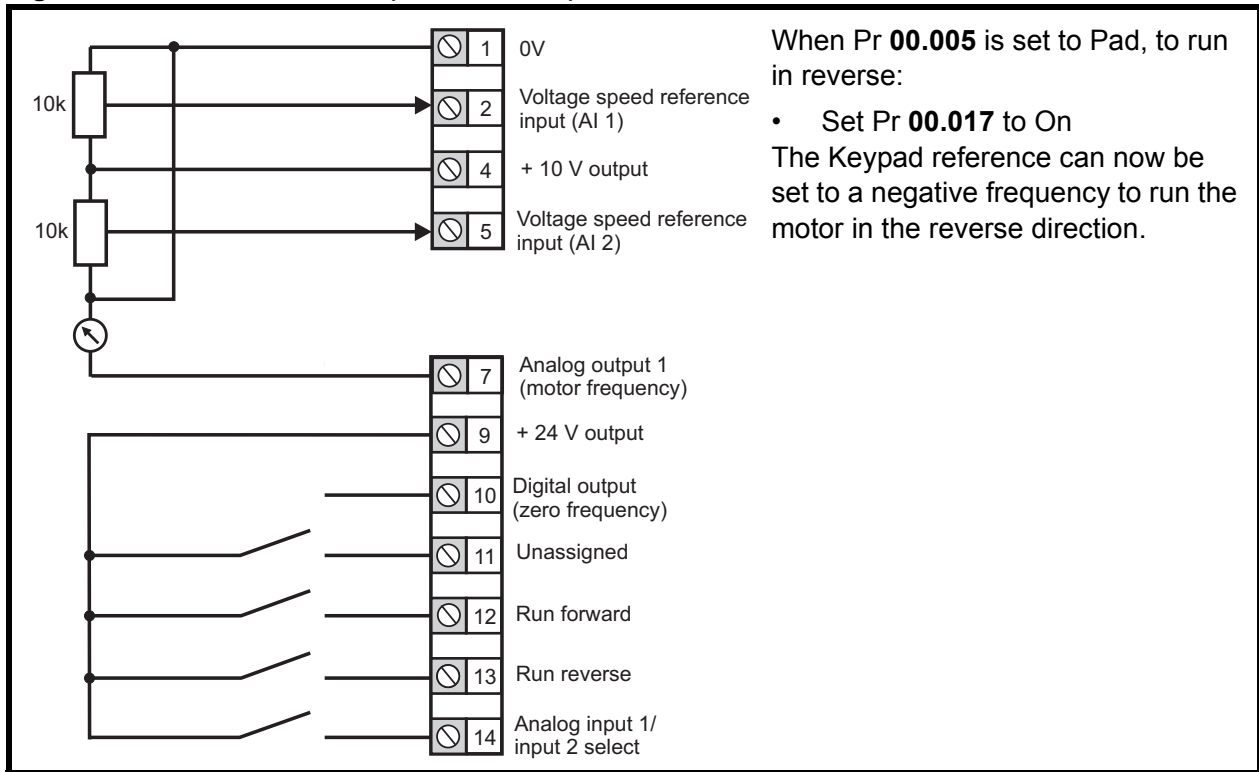




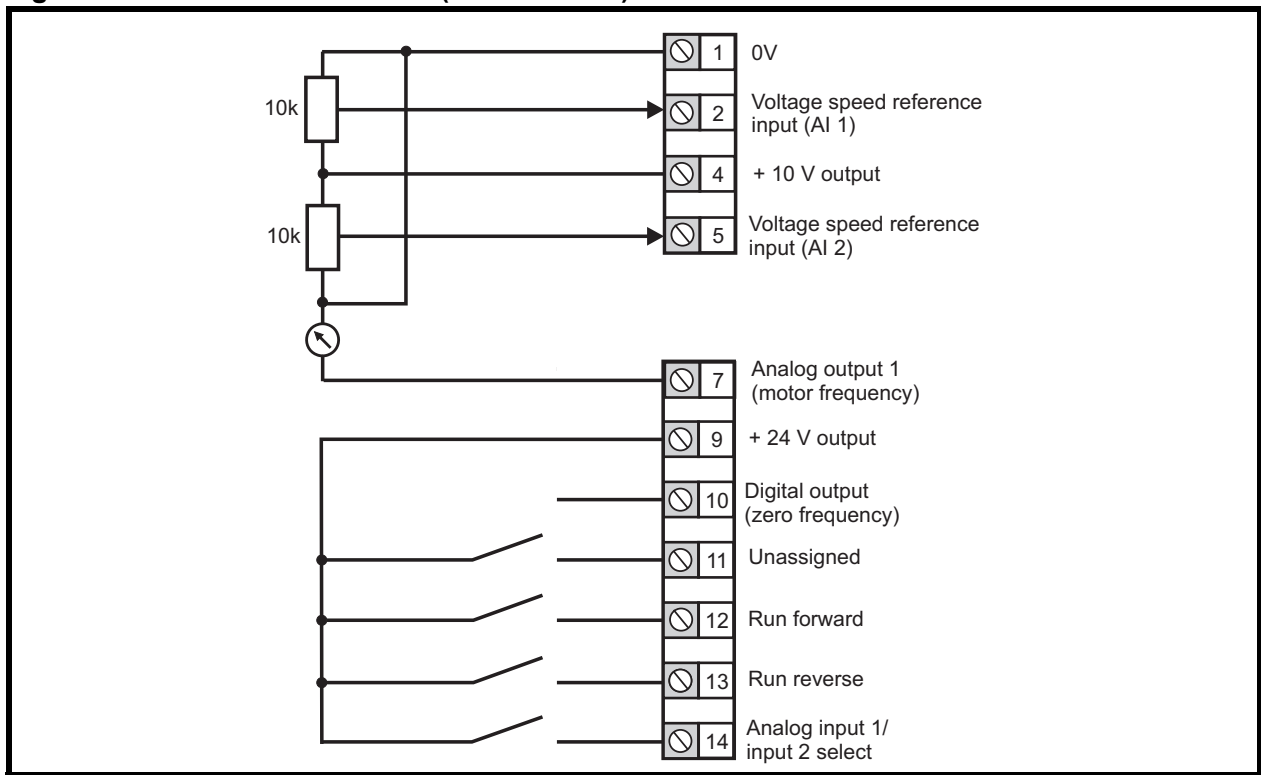
**Figure 4-5 Pr 00.005 = Preset (50 and 60 Hz)**



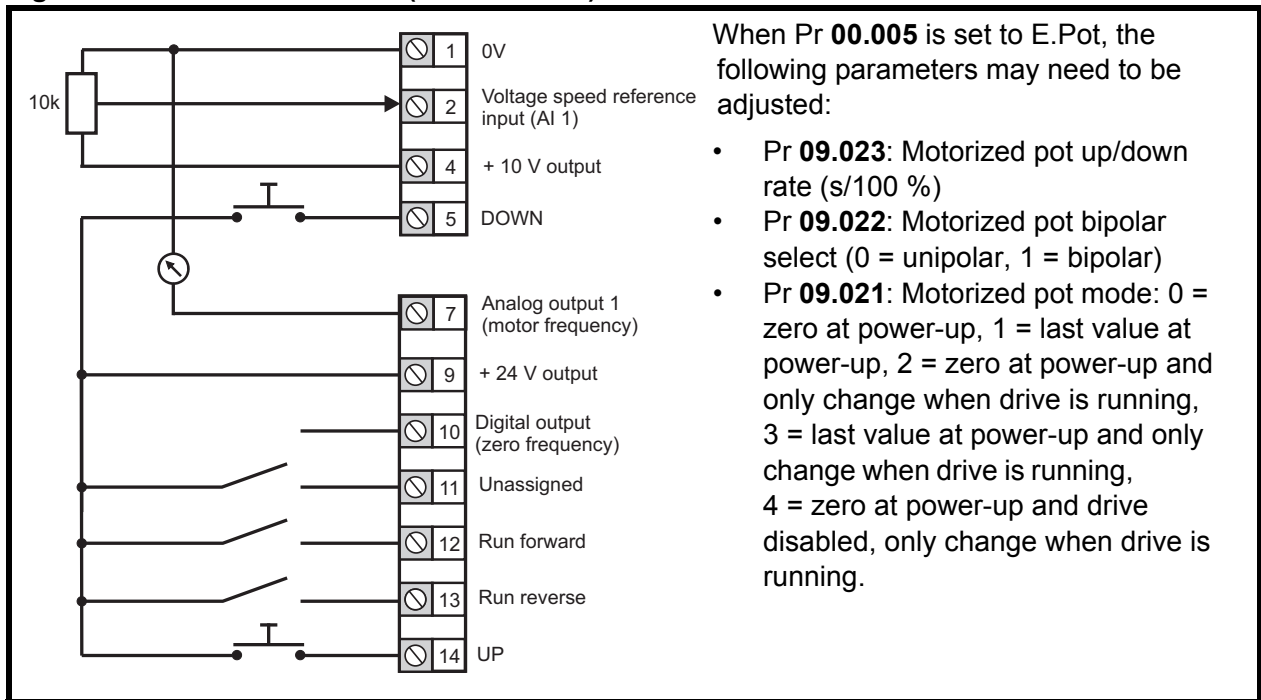
**Figure 4-6 Pr 00.005 = Pad (50 and 60 Hz)**



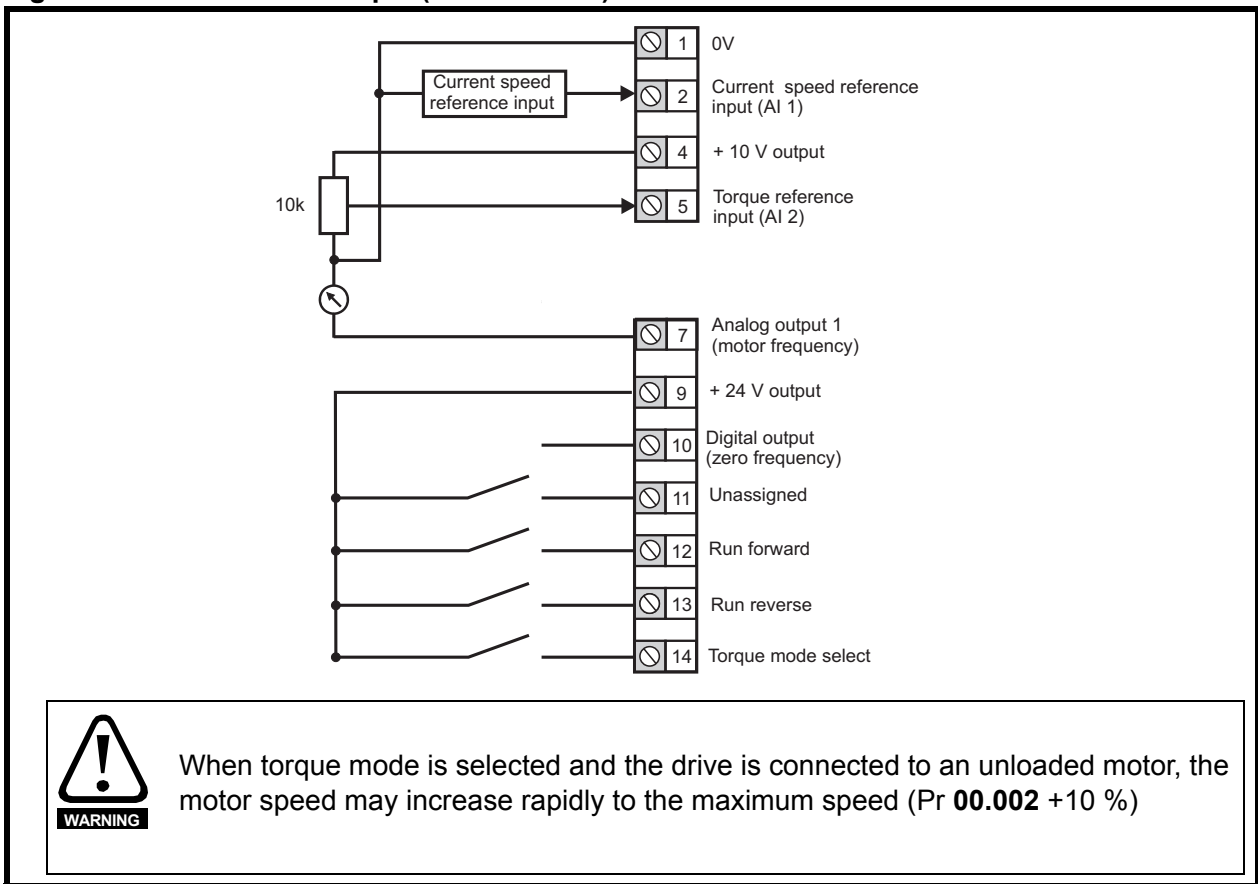
**Figure 4-7 Pr 00.005 = Pad.Ref (50 and 60 Hz)**



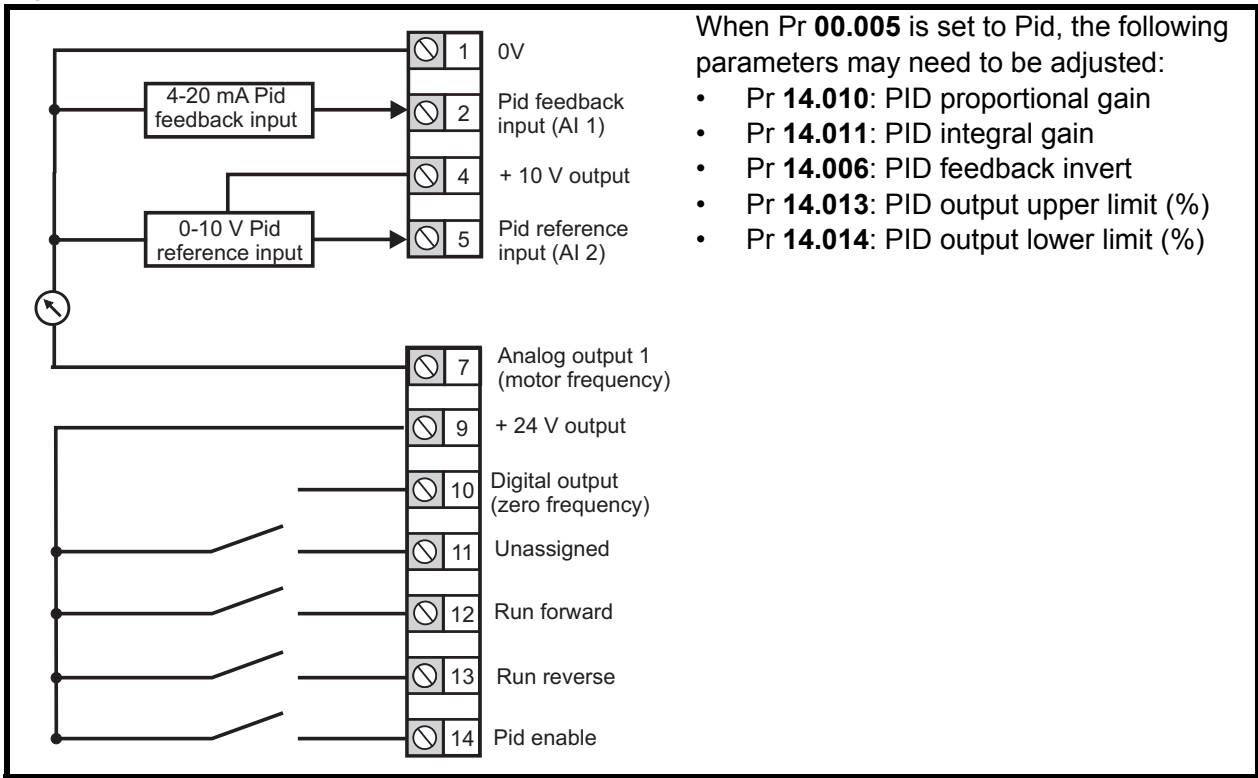
**Figure 4-8 Pr 00.005 = E.Pot (50 and 60 Hz)**



**Figure 4-9 Pr 00.005 = torque (50 and 60 Hz)**



**Figure 4-10 Pr 00.005 = Pid (50 and 60 Hz)**



## 4.5 EMC

### 4.5.1 Internal EMC filter

It is recommended that the internal EMC filter be kept in place unless there is a specific reason for removing it. If the drive is used as a motoring drive as part of a regen system, then the internal EMC filter must be removed.

The internal EMC filter reduces radio-frequency emission into the line power supply.

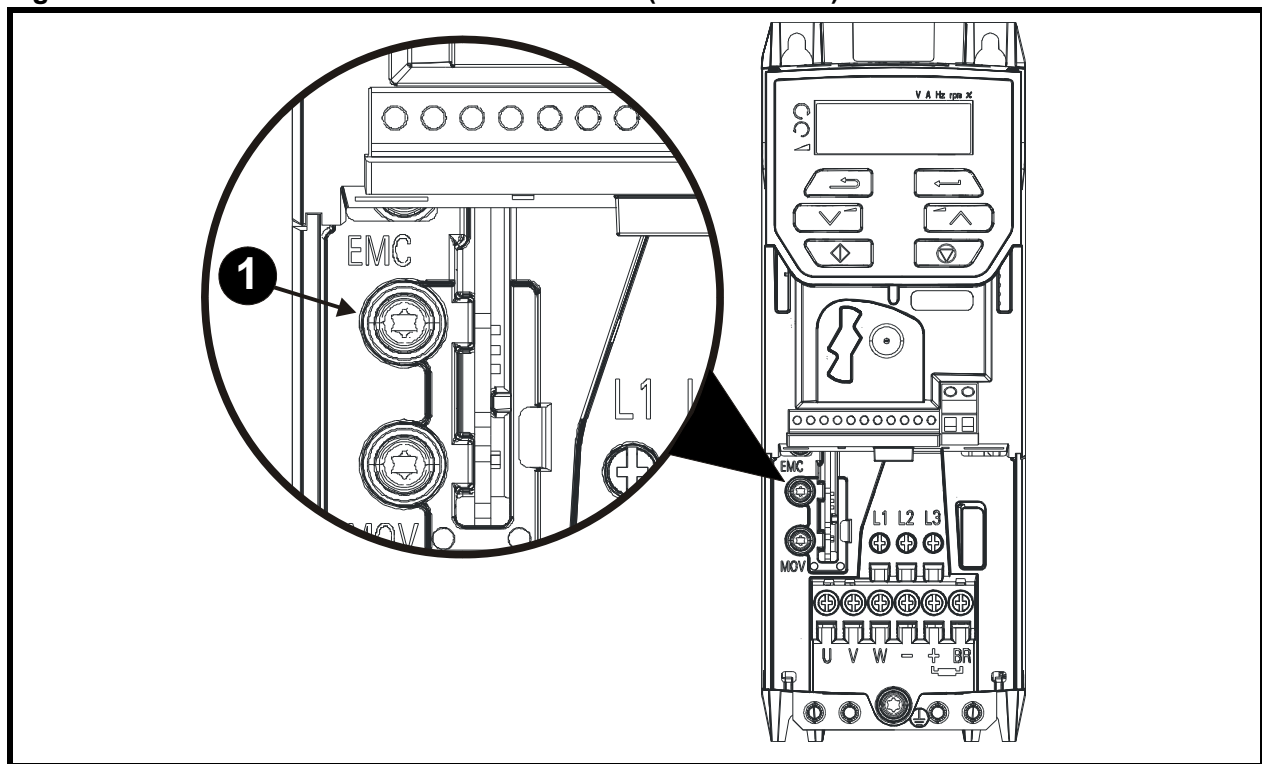
For longer motor cables, the filter continues to provide a useful reduction in emission levels and when used with any length of shielded motor cable up to the limit for the drive, it is unlikely that nearby industrial equipment will be disturbed. It is recommended that the filter be used in all applications unless the instructions given above require it to be removed, or where the ground leakage current is unacceptable.

### 4.5.2 Removing the internal EMC filter



The supply must be disconnected before removing the internal EMC filter.

Figure 4-11 Removal of the internal EMC filter (size 2 shown)



To electrically disconnect the internal EMC filter, remove the screw as shown above (1).

### 4.5.3 Further EMC precautions

Further EMC precautions are required if more stringent EMC emission requirements apply:

- Operation in the first environment of EN 61800-3: 2004
- Conformity to the generic emission standards
- Equipment which is sensitive to electrical interference operating nearby

In this case it is necessary to use:

- The optional external EMC filter
- A shielded motor cable, with shield clamped to the grounded metal panel

- A shielded control cable, with shield clamped to the grounded metal panel  
Full instructions are given in the *Drive User Guide*.

A full range of external EMC filters are also available for use with *Unidrive M300*.

## 4.6 SAFE TORQUE OFF (STO)

The SAFE TORQUE OFF function provides a means for preventing the drive from generating torque in the motor with a very high level of integrity. It is suitable for incorporation into a safety system for a machine. It is also suitable for use as a conventional drive enable input.

The safety function is active when either one or both STO inputs are in the logic-low state as specified in the control terminal specification. The function is defined according to EN 61800-5-2 and IEC 61800-5-2 as follows. (In these standards a drive offering safety-related functions is referred to as a PDS(SR)):

*'Power, that can cause rotation (or motion in the case of a linear motor), is not applied to the motor. The PDS(SR) will not provide energy to the motor which can generate torque (or force in the case of a linear motor).'*

This safety function corresponds to an uncontrolled stop in accordance with stop category 0 of IEC 60204-1. The SAFE TORQUE OFF function makes use of the special property of an inverter drive with an induction motor, which is that torque cannot be generated without the continuous correct active behavior of the inverter circuit. All credible faults in the inverter power circuit cause a loss of torque generation.

The SAFE TORQUE OFF function is fail-safe, so when the SAFE TORQUE OFF input is disconnected the drive will not operate the motor, even if a combination of components within the drive has failed. Most component failures are revealed by the drive failing to operate. SAFE TORQUE OFF is also independent of the drive firmware.



The design of safety-related control systems must only be done by personnel with the required training and experience. The SAFE TORQUE OFF function will only ensure the safety of a machine if it is correctly incorporated into a complete safety system. The system must be subject to a risk assessment to confirm that the residual risk of an unsafe event is at an acceptable level for the application



SAFE TORQUE OFF does not provide electrical isolation. The supply to the drive must be disconnected by an approved isolation device before gaining access to power connections.



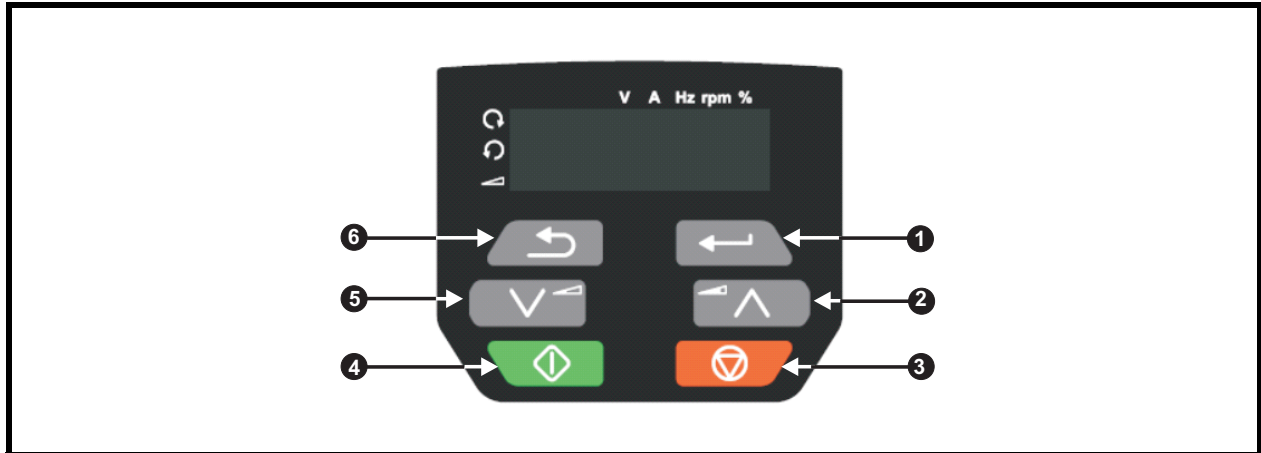
It is essential to observe the maximum permitted voltage of 5 V for a safe low (disabled) state of SAFE TORQUE OFF. The connections to the drive must be arranged so that voltage drops in the 0 V wiring cannot exceed this value under any loading condition. It is strongly recommended that the SAFE TORQUE OFF circuits be provided with a dedicated 0 V conductors which should be connected to terminals 32 and 33 at the drive.

For more information regarding the SAFE TORQUE OFF input, please see the *Drive User Guide*.

## 5 Keypad and display

The keypad and display provide information to the user regarding the operating status of the drive and trip codes, and provide the means for changing parameters, stopping and starting the drive, and the ability to perform a drive reset.

**Figure 5-1 Unidrive M300 keypad detail**



- (1) The Enter button is used to enter parameter view or edit mode, or to accept a parameter edit.
- (2, 5) The Navigation keys can be used to select individual parameters or to edit parameter values. In keypad mode, the 'Up' and 'Down' keys are also used to increase or decrease the motor speed.
- (3) The Stop / Reset button is used to stop and reset the drive in keypad mode. It can also be used to reset the drive in terminal mode.
- (4) The Start button is used to start the drive in keypad mode.
- (6) The Escape button is used to exit from the parameter edit / view mode or disregard a parameter edit.

**Table 5-1 Status indications**

String	Description	Drive output stage
<b>inh</b>	The drive is inhibited and cannot be run. The SAFE TORQUE OFF signal is not applied to SAFE TORQUE OFF terminals or Pr <b>06.015</b> is set to 0.	Disabled
<b>rdy</b>	The drive is ready to run. The drive enable is active, but the drive inverter is not active because the final drive run is not active.	Disabled
<b>Stop</b>	The drive is stopped / holding zero speed.	Enabled
<b>S.Loss</b>	Supply loss condition has been detected.	Enabled
<b>dc.inj</b>	The drive is applying dc injection braking.	Enabled
<b>Er</b>	The drive has tripped and no longer controlling the motor. The trip code appears in the display.	Disabled
<b>UV</b>	The drive is in the under voltage state either in low voltage or high voltage mode.	Disabled

## 5.1 Saving parameters

When changing a parameter in Menu 0, the new value is saved when pressing the Enter button




to return to parameter view mode from parameter edit mode.

If parameters have been changed in the advanced menus, then the change will not be saved automatically. A save function must be carried out.

### Procedure

1. Select 'Save\*' in Pr **mm.000** (alternatively enter a value of 1000\* in Pr **mm.000**)
2. Either:

- Press the red  reset button
- Carry out a drive reset through serial communications by setting Pr **10.038** to 100

\* If the drive is in the under voltage state (i.e. when the AI-Backup adaptor terminals are being supplied from a +24 Vdc supply) a value of 1001 must be entered into Pr **mm.000** to perform a save function.


## 5.2 Restoring parameter defaults

Restoring parameter defaults by this method saves the default values in the drives memory. *User security status* (00.010) and *User security code* (00.025) are not affected by this procedure).

### Procedure

1. Ensure the drive is not enabled, i.e. terminal 31 & 34 is open or Pr **06.015** is OFF (0)
2. Select 'Def.50' or 'Def.60' in Pr **mm.000**. (alternatively, enter 1233 (50 Hz settings) or 1244 (60 Hz settings) in Pr **mm.000**).

3. Either:

- Press the red  reset button
- Carry out a drive reset through serial communications by setting Pr **10.038** to 100

## 6 Basic parameters (Menu 0)

Menu 0 is used to bring together various commonly used parameters for basic easy set up of the drive. All the parameters in Menu 0 appear in other menus in the drive (denoted by {...}). Menus 22 can be used to configure the parameters in Menu 0.

### 6.1 Menu 0: Basic parameters

Parameter		Range(⇅)		Default(⇨)		Type					
		OL	RFC-A	OL	RFC-A						
00.001	Minimum Reference Clamp	±VM_NEGATIVE_REF_CLAMP1 Hz		0.00 Hz		RW	Num				US
00.002	Maximum Reference Clamp	±VM_POSITIVE_REF_CLAMP Hz		50Hz default: 50.00 Hz 60Hz default: 60.00 Hz		RW	Num				US
00.003	Acceleration Rate 1	±VM_ACCEL_RATE s		5.0 s		RW	Num				US
00.004	Deceleration Rate 1	±VM_ACCEL_RATE s		10.0 s		RW	Num				US
00.005	Drive Configuration	AV (0), AI (1), AV.Pr (2), AI.Pr (3), Preset (4), Pad (5), Pad.Ref (6), E.Pot (7), torque (8), Pid (9)		AV (0)		RW	Txt			PT	US
00.006	Motor Rated Current	±VM_RATED_CURRENT A		Maximum Heavy Duty Rating (11.032) A		RW	Num		RA		US
00.007	Motor Rated Speed	0.0 to 80000.0 rpm		50Hz default: 1500.0 rpm 60Hz default: 1800.0 rpm	50Hz default: 1450.0 rpm 60Hz default: 1750.0 rpm	RW	Num				US
00.008	Motor Rated Voltage	±VM_AC_VOLTAGE_SET V		110V drive: 230 V 200V drive: 230 V 400V drive 50 Hz: 400 V 400V drive 60 Hz: 460 V 575V drive: 575 V 690V drive: 690 V		RW	Num		RA		US
00.009	Motor Rated Power Factor	0.00 to 1.00		0.85		RW	Num		RA		US
00.010	User Security Status	LEVEL.0 (0), ALL (1), r.only.0 (2), r.only.A (3), Status (4), no.acc(5)		LEVEL.0 (0)		RW	Num	ND	NC	PT	
00.015	Jog Reference	0.00 to 300.00 Hz		1.50 Hz		RW	Num				US
00.016	Analog Input 1 Mode	4-20.S (-6), 20-4.S (-5), 4-20.L (-4), 20-4.L (-3), 4-20.H (-2), 20-4.H (-1), 0-20 (0), 20-0 (1), 4-20.tr (2), 20-4.tr (3), 4-20 (4), 20-4 (5), Volt (6)		Volt (6)		RW	Txt				US
00.017	Bipolar Reference Enable	Off (0) or On (1)		Off (0)		RW	Bit				US
00.018	Preset Reference 1	±VM_SPEED_FREQ_REF Hz		0.00 Hz		RW	Num				US
00.025	User Security Code	0 to 9999		0		RW	Num	ND	NC	PT	US
00.027	Power-up Keypad Control Mode Reference	Reset (0), Last (1), Preset (2)		Reset (0)		RW	Txt				US



Parameter		Range(⇅)		Default(⇔)		Type					
		OL	RFC-A	OL	RFC-A						
00.028	Ramp Mode Select	Fast (0), Std (1), Std.bst (2), Fst.bst (3)		Std (1)		RW	Txt				US
00.029	Ramp Enable		Off (0) or On (1)		On (1)	RW	Bit				US
00.030	Parameter Cloning	None (0), rEAd (1), Prog (2), Auto (3), boot (4)		None (0)		RW	Txt		NC		US
00.031	Stop Mode	Coast (0), rp (1), rp.dc I (2), dc I (3), td.dc I (4), dis (5), No.rp (6)		rp (1)		RW	Txt				US
00.032	Dynamic V to F Select / Flux Optimization Select	0 to 1		0		RW	Num				US
00.033	Catch A Spinning Motor	dis (0), Enable (1), Fr.Only (2), Rv.Only (3)		dis (0)		RW	Txt				US
00.034	Digital Input 5 Select	Input (0), th.Sct (1), th (2), th.NoTr (3), Fr (4)		Input (0)		RW	Txt				US
00.035	Digital Output 1 Control	0 to 21		0		RW					US
00.036	Analog Output 1 Control	0 to 15		0		RW					US
00.037	Maximum Switching Frequency	0.667 (0), 1(1), 2 (2), 3 (3), 4 (4), 6 (5), 8 (6), 12 (7), 16 (8) kHz	2 (2), 3 (3), 4 (4), 6 (5), 8 (6), 12 (7), 16 (8) kHz	3 (3) kHz		RW	Txt				US
00.038	Auto-tune	0 to 2	0 to 3	0		RW	Num		NC		US
00.039	Motor Rated Frequency	0.00 to VM_SPEED_FREQ_REF_UNIPOLAR Hz		50Hz: 50.00 Hz 60Hz: 60.00 Hz		RW	Num		RA		US
00.040	Number of Motor Poles*	Auto (0) to 32 (16)		Auto 0		RW	Num				US
00.041	Control Mode	Ur.S (0), Ur (1), Fd (2), Ur.Auto (3), Ur.I (4), SrE (5)		Ur.I (4)		RW	Txt				US
00.042	Low Frequency Voltage Boost	0.0 to 25.0 %		3.0 %		RW	Num				US
00.043	Serial Baud Rate	300 (0), 600 (1), 1200 (2), 2400 (3), 4800 (4), 9600 (5), 19200 (6), 38400 (7), 57600 (8), 76800 (9), 115200 (10)		19200 (6)		RW	Txt				US
00.044	Serial Address	1 to 247		1		RW	Num				US
00.045	Reset Serial Communications	Off (0) or On (1)		Off (0)		RW		ND	NC		
00.046	Brake Release Current Threshold	0 to 200 %		50 %		RW	Num				US
00.047	Brake Apply Current Threshold	0 to 200 %		10 %		RW					US
00.048	BC Brake Release Frequency	0.00 to 20.00 Hz		1.00 Hz		RW	Num				US
00.049	BC Brake Apply Frequency	0.00 to 20.00 Hz		2.00 Hz		RW	Num				US
00.050	BC Brake Delay	0.0 to 25.0 s		1.00 s		RW	Num				US
00.051	BC Post-brake Release Delay	0.0 to 25.0 s		1.00 s		RW	Num				US

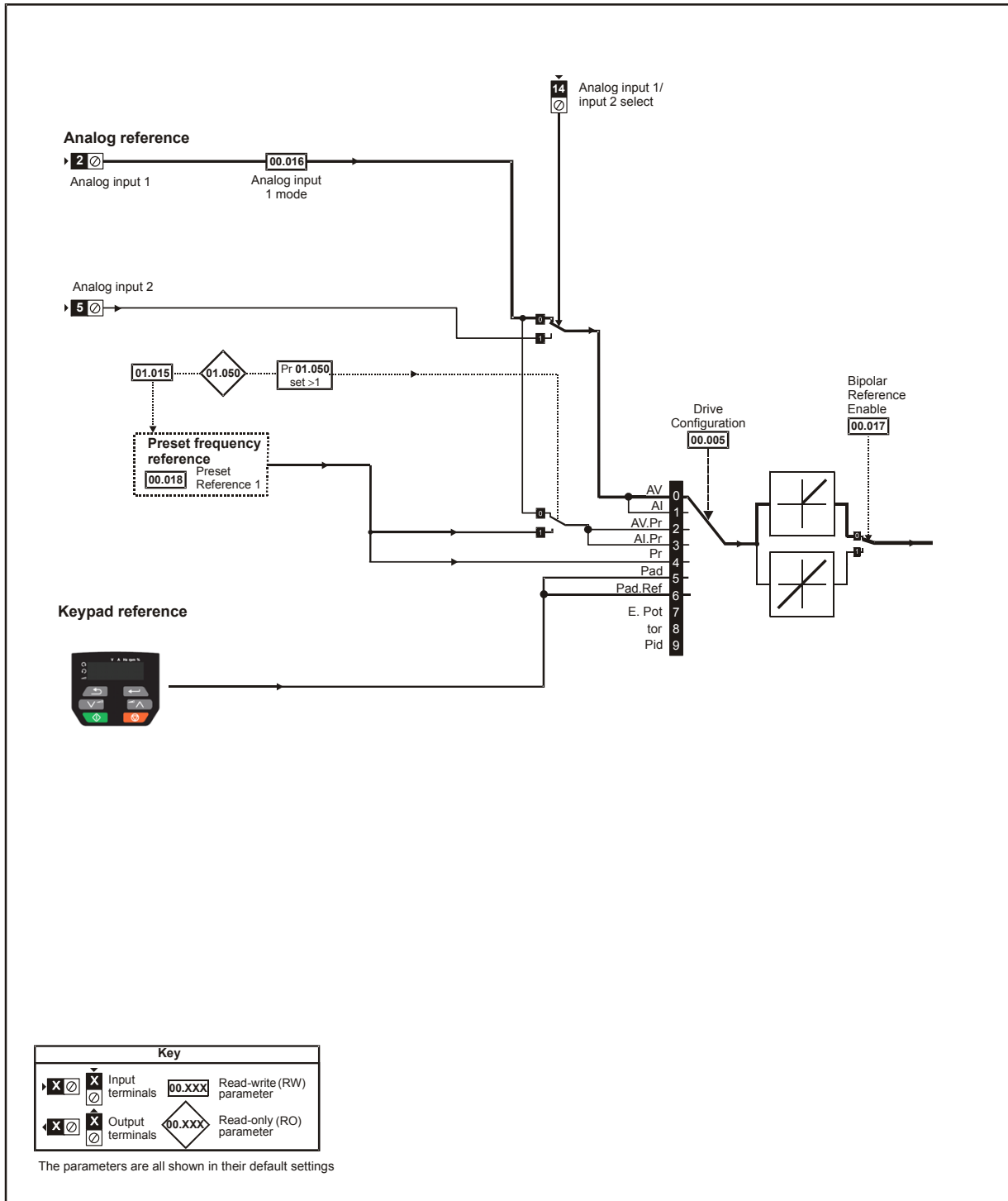
Parameter		Range(⇅)		Default(⇄)		Type						
		OL	RFC-A	OL	RFC-A							
00.053	BC Initial Direction	Ref (0), For (1), Rev (2)		Ref (0)		RW	Txt					US
00.054	BC Brake Apply Through Zero Threshold	0.00 to 25.00 Hz		0.00 Hz		RW	Num					US
00.055	BC Enable	dis (0), Relay (1), dig IO (2), User (3)		dis (0)		RW	Txt					US
00.065	Frequency Controller Proportional Gain Kp1		0.000 to 200.000 s/rad		0.100 s/rad	RW	Num					US
00.066	Frequency Controller Integral Gain Ki1		0.00 to 655.35 s <sup>2</sup> /rad		0.10 s <sup>2</sup> /rad	RW	Num					US
00.067	Sensorless Mode Filter		4 (0), 5 (1), 6 (2), 8 (3), 12 (4), 20 (5) ms		4 (0) ms	RW	Txt					US
00.069	Spin Start Boost	0.0 to 10.0		1.0		RW						US
00.076	Action on Trip Detection	0 to 31		0		RW						US
00.077	Maximum Heavy Duty Current Rating	0.00 to 9999.99 A				RO	Num	ND	NC	PT		
00.078	Software Version	0 to 999999				RO		ND	NC	PT		
00.079	User Drive Mode	OPEn.LP (1), RFC-A (2)		OPEn.LP (1)		RW	Txt	ND	NC	PT		US
00.080	User Security Status	LEVEL.0 (0), ALL (1), r.only.0 (2), r.only.A (3), Status (4), no.acc(5)		LEVEL.O. (0)		RW	Txt	ND				PT

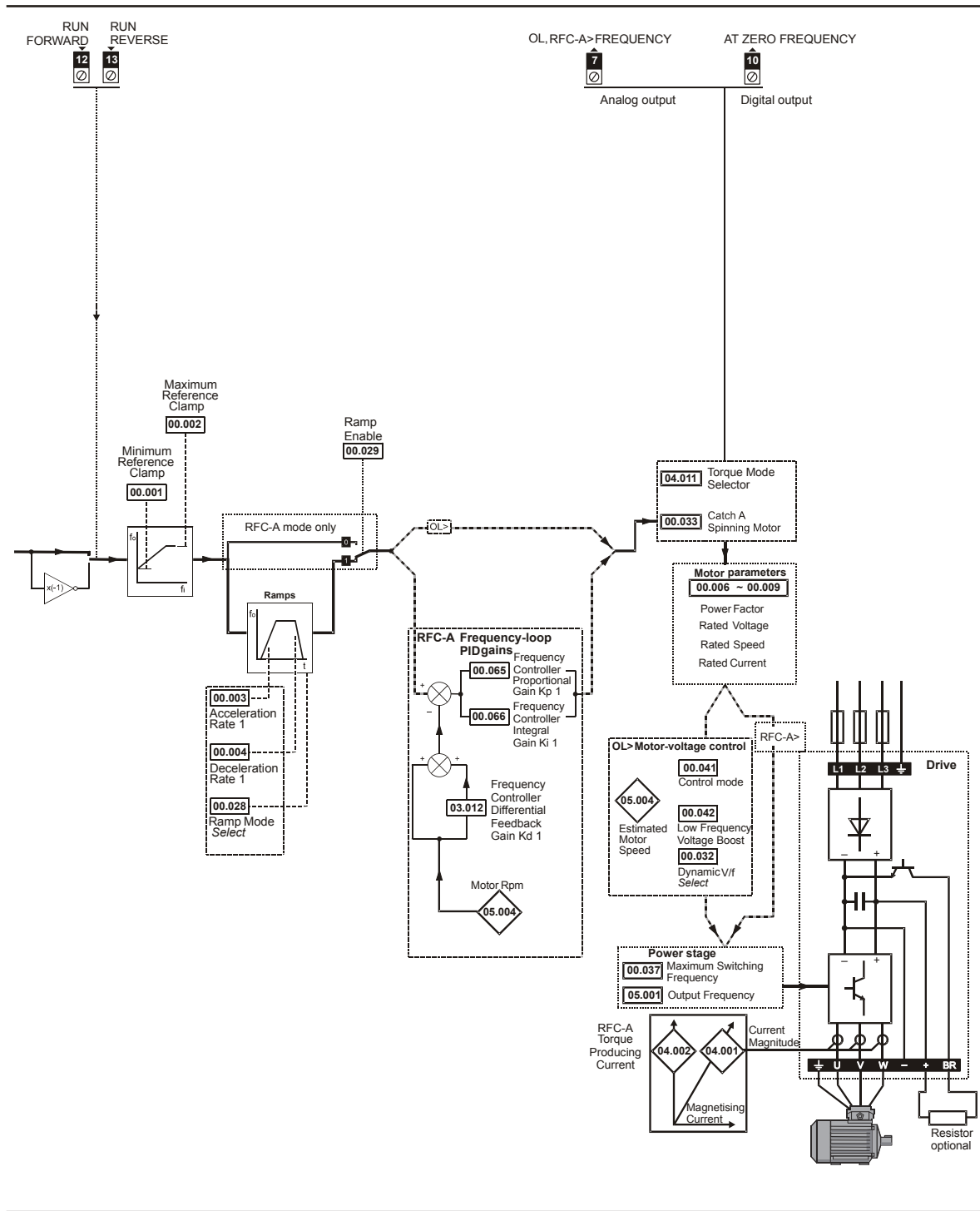
\* If this parameter is read via serial communications, it will show pole pairs.

RW	Read / Write	RO	Read only	Num	Number parameter	Bit	Bit parameter	Txt	Text string	Bin	Binary parameter	FI	Filtered
ND	No default value	NC	Not copied	PT	Protected parameter	RA	Rating dependent	US	User save	PS	Power-down save	DE	Destination



**Figure 6-1 Menu 0 logic diagram**





# 7 Running the motor

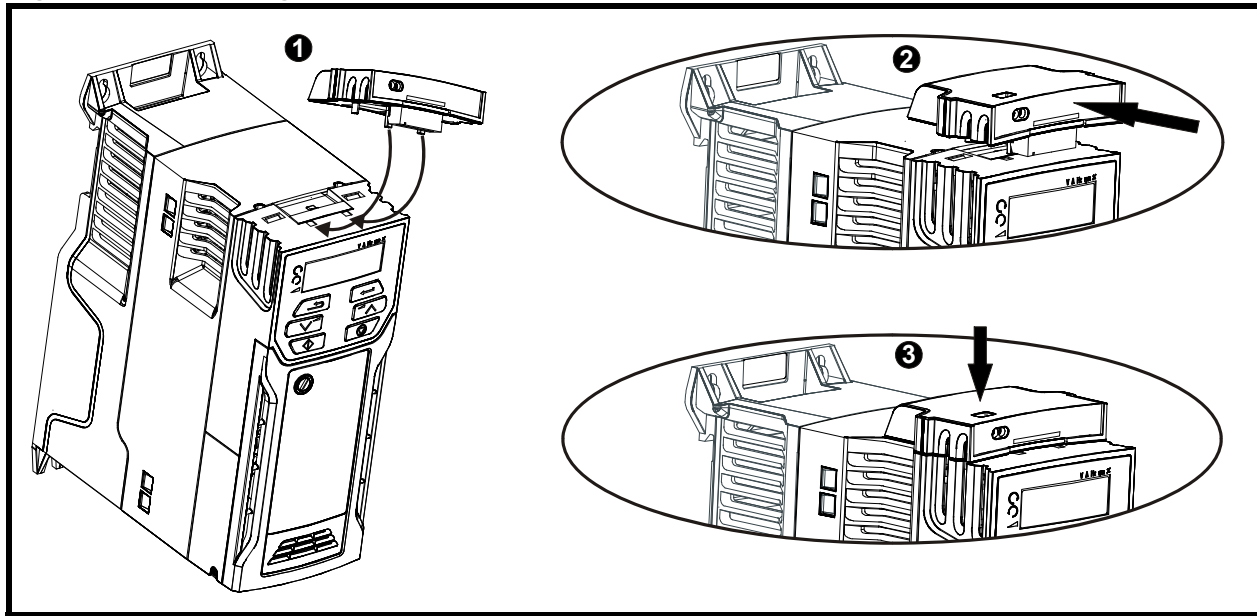
This section takes a new user through all the essential steps to running a motor for the first time.

**Table 7-1 Open Loop and RFC-A**

Action	Detail	
Before power up	Ensure: <ul style="list-style-type: none"> <li>The drive enable signal is not given, terminal 31 and 34 is open</li> <li>The run signal is not given, terminal 12/13 is open</li> <li>The motor is connected to the drive</li> <li>The motor connection is correct for the drive <math>\Delta</math> or Y</li> <li>The correct supply voltage is connected to the drive</li> </ul>	
Power up the drive	The default setting is Open Loop vector mode. For RFC-A mode set Pr <b>00.079</b> to RFC-A, then press the  stop/reset button to save the parameters. Ensure: The drive displays: Inh	
Enter minimum and maximum speeds	Enter: <ul style="list-style-type: none"> <li>Minimum speed Pr <b>00.001</b> (Hz)</li> <li>Maximum speed Pr <b>00.002</b> (Hz)</li> </ul>	
Enter accel and decel rates	Enter: <ul style="list-style-type: none"> <li>Acceleration rate Pr <b>00.003</b> (s/100 Hz)</li> <li>Deceleration rate Pr <b>00.004</b> (s/100 Hz)</li> </ul>	
Enter motor nameplate details	Enter: <ul style="list-style-type: none"> <li>Motor rated current in Pr <b>00.006</b> (A)</li> <li>Motor rated speed in Pr <b>00.007</b> (rpm)</li> <li>Motor rated voltage in Pr <b>00.008</b> (V)</li> <li>Motor rated power factor in Pr <b>00.009</b></li> <li>If the motor is not a standard 50/60 Hz motor, set Pr <b>00.039</b> accordingly</li> </ul>	
<b>Ready to autotune</b>		
Autotune	The drive is able to perform either a stationary or a rotating autotune. The motor must be at a standstill before an autotune is enabled. To perform an autotune: <ul style="list-style-type: none"> <li>Set Pr <b>00.038</b> = 1 for a stationary autotune or set Pr <b>00.038</b> = 2 for a rotating autotune</li> <li>Close the drive enable signal (apply +24 V to terminal 31 &amp; 34). The drive will display 'Rdy'.</li> <li>Close the run signal (apply +24 V to terminal 12 or 13). The display will flash 'tuning' while the drive is performing the autotune.</li> <li>Wait for the drive to display 'Inh' and for the motor to come to a standstill.</li> <li>Remove the drive enable and run signal from the drive.</li> </ul>	
Autotune complete	When the autotune has been completed, Pr <b>00.038</b> will be set to 0	
Tuning of frequency controller gains (RFC-A mode only)	Depending on the application, the frequency controller gains (Pr <b>03.010</b> , Pr <b>03.011</b> and Pr <b>03.012</b> ) may need to be adjusted.	
<b>Save parameters</b>		
Save parameters	Select 'SAVE' in Pr <b>mm.000</b> (alternatively enter a value of 1000) and press the  Stop / Reset button to save parameters.	
<b>Ready to run</b>		
Run	The drive is now ready to run the motor.	
Increasing and decreasing speed	Turning the speed potentiometer will increase and decrease the speed of the motor.	
Stopping	To stop the motor under ramp control, open either the run forward or run reverse terminal. If the enable terminal is opened while the motor is running, the motor will coast to a stop.	

# 8 NV Media Card Operation

Figure 8-1 Installing the AI-Backup adaptor (SD Card)



1. Identify the two plastic fingers on the underside of the AI-Backup adaptor (1) - then insert the two fingers into the corresponding slots in the spring-loaded sliding cover on the top of the drive.
2. Hold the adaptor firmly and push the spring loaded protective cover towards the back of the drive to expose the connector block (2) below.

Press the adaptor downwards (3) until the adaptor connector locates into the drive connection below.

Figure 8-2 Basic NV Media Card operation

<p>Drive reads all parameters from the NV Media Card</p> <p><b>Pr 00.030 = rEAd +</b> </p>	<p>Programs all drive parameters to the NV Media Card</p> <p><b>NOTE</b> Overwrites any data already in data block 1</p> <p><b>Pr 00.030 = Prog +</b> </p>
<p>Drive automatically writes to the Media Card when a parameter save is performed</p> <p><b>Pr 00.030 = Auto +</b> </p>	<p>Drive boots from the NV Media Card on power up and automatically writes to the Media Card when a parameter save is performed</p> <p><b>Pr 00.030 = boot +</b> </p>

The whole card may be protected from writing or erasing by setting the read-only flag, refer to the *Drive User Guide* for further information. The card should not be removed during data transfer, as the drive will produce a trip. If this occurs then either the transfer should be reattempted or in the case of a card to drive transfer, default parameters should be loaded.

## 9 UL listing information

### 9.1 General

Drive sizes 1 to 4 have been assessed to meet both UL and cUL requirements.

UL listings can be viewed online at [www.UL.com](http://www.UL.com). The UL file number is E171230.

### 9.2 Mounting

Drives can be installed in the following configurations:

- Standard or surface mounted. Refer to the *Drive User Guide* for further information.
- Bookcase mounted. Drives are mounted side by side with no space between them. This configuration minimizes the overall width of the installation.

### 9.3 Environment

Drives are able to meet the following UL/NEMA environmental ratings:

- Type 1. The drive must either be installed with a UL Type 1 kit or be installed in a Type 1 enclosure.
- Type 12. The drive must be installed in a Type 12 enclosure.
- The remote keypad is rated to both UL Type 1 and UL Type 12.
- Drives must be installed in a pollution degree 2 environment or better.

### 9.4 Electrical ratings

Suitable for use on a circuit capable of delivering not more than 100,000 RMS symmetrical amperes, at the rated maximum AC voltage.

For information on power and current ratings, see the *Drive User Guide*.

Fuse and circuit breaker (size 1 only with short circuit rating of 10 kA) ratings are given in the *Drive User Guide*.

Unless indicated otherwise in the *Drive User Guide*, fuses may be any UL listed Class J or CC with a voltage rating of at least 600 Vac.

Unless indicated otherwise in the *Drive User Guide*, circuit breakers may be any UL listed type, category control number: DIVQ or DIVQ7, with a voltage rating of at least 600 Vac.

### 9.5 Opening of branch circuit

The opening of the branch-circuit protective device may be an indication that a fault has been interrupted. To reduce the risk of fire or electric shock, the equipment may be examined and replaced if damaged. If burnout of the current element of an overload relay occurs, the complete overload relay must be replaced.

Integral solid state short circuit protection does not provide branch circuit protection. Branch circuit protection must be provided in accordance with the National Electrical Code and any additional local "codes", or the equivalent.

### 9.6 Electrical installation

The following precautions must be observed:

- Drives are rated for use at 40 °C and 50 °C surrounding air temperature.
- Field wiring terminals are suitable for copper wire only, which must have a temperature rating of at least 75 °C.
- If the drive control stage is powered from an external power supply (+24 V), the power supply must be listed or recognized to UL class 2 with appropriate fusing.
- Ground connections must use UL listed closed loop (ring) terminals.



## 9.7 cUL requirements for frame size 4

For frame size 4, models Mxxx-042 00133A, Mxxx-042 00176A, Mxxx-044 00135A and Mxxx-044 00170A, transient surge suppression shall be installed on the line side of this equipment and shall be rated 480 Vac (phase to ground), 480 Vac (phase to phase), suitable for overvoltage category III, and shall provide protection for a rated impulse withstand voltage peak of 6 kV and a clamping voltage of maximum 2400 V.

### NOTE

Mxxx denotes M100, M101, M200, M201, M300 or M400.

## 9.8 Motor overload protection

All models incorporate internal overload protection for the motor load that does not require the use of an external or remote overload protection device. The protection level is adjustable and the method of adjustment is provided within instructions/manual for the product. Maximum current overload is dependent on the values entered into the current limit parameters (*Motoring Current Limit* (04.005), *Regenerative Current Limit* (04.006) and *Symmetrical Current Limit* (04.007) entered as percentage) and the *Motor Rated Current* (00.006) entered in amperes). The duration of the overload is dependent on *Motor Thermal Time Constant* (04.015) variable up to a maximum of 3000 seconds. The default overload protection is set such that the product is capable of 150 % of the current value entered into the motor rated current parameter for 60 seconds. The product can be connected to a motor thermistor to protect the motor, in the event of a motor cooling fan failure.

## 9.9 Motor overspeed protection

The drive is installed with solid state motor overspeed protection.

However, this feature does not provide the level of protection provided by an independent, high-integrity overspeed protection device and should not be considered as a safety function.

## 9.10 Thermal memory retention

Drives incorporate thermal memory retention that complies fully with the requirements of UL508C.

The drive is provided with motor load and speed sensitive overload protection with thermal memory retention that complies with the US National Electrical Code (NFPA 70) clause 430.126 and Underwriters Laboratories Standard UL508C, clause 20.1.11 (a). The purpose of this protection is to protect both drive and motor from dangerous overheating in the event of repeated overload or failure to start, even if the power to the drive is removed between overload events.

For full explanation of the thermal protection system, refer to the *Drive User Guide* for further information.

In order to comply with UL requirements for thermal memory retention, it is necessary to set the *Thermal Protection Mode* (04.016) to zero; and the *Low Frequency Thermal Protection Mode* (04.025) must be set to 1 if the drive is operated in Heavy Duty mode.

Alternatively, an external thermal sensor or switch may be used as a means of motor and drive overload protection that complies with the requirements of UL508C, clause 20.1.11 (b). This protection method is particularly recommended where independent forced cooling of the motor is used, because of the risk of overheating if the cooling is lost.

### External thermal sensor

The drive is provided with a means to accept and act upon a signal from a thermal sensor or switch imbedded in the motor or from an external protective relay. Refer to the *Drive User Guide* for further information.

## 9.11 Group installation

### 9.11.1 Definition

Group Installation Definition: A motor branch circuit for two or more motors, or one or more motors with other loads, protected by a circuit breaker or a single set of fuses.

### 9.11.2 Limitations on use

#### All motors rated less than 1 hp

The drives may be used in group installations where each of the motors is rated 1 hp or less. The full-load current rating of each motor must not exceed 6 A. The motor drive provides individual overload protection in accordance with the NEC clause 430.32.

#### Smallest motor protected

The drives may be used in group installations where the smallest motor is protected by the branch fuses or circuit breaker. Limits on the current rating of branch circuit protective fuses and circuit breakers are given in the NEC Table: 430.52.

#### Other installations

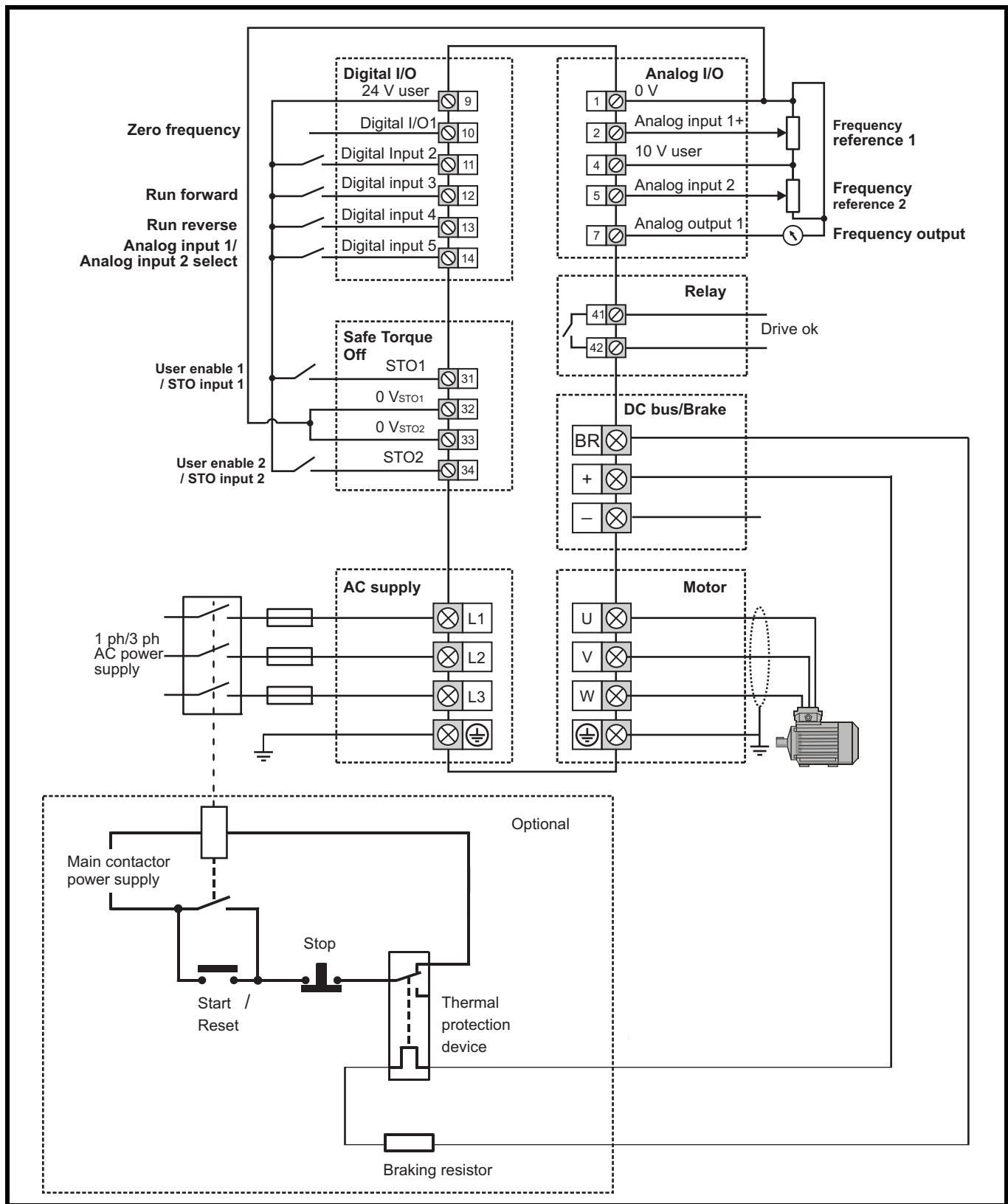
The motor drives described in this user guide are not UL listed for group installation.

## 9.12 UL listed accessories

The following options are UL listed:

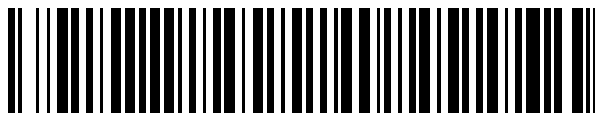
- AI-485 Adaptor
- AI-Backup Adaptor
- Remote Keypad
- UL Type 1 kit
- NV Media card
- SI-PROFIBUS
- SI-DeviceNet
- SI-CANopen
- SI-EtherNet
- SI-EtherCAT
- SI-I/O





**NOTE**

The 0 V terminals on the SAFE TORQUE OFF are isolated from each other and the 0 V common. On the size 2 110 V drives or when connecting single phase to a dual rated 200 V unit, the supply should be connected to L1 and L3.



0478-0039-05